

Brisbane Hockey Association Inc.



Competition Rules and Requirements

November 9th 2008

Table of Contents

1	BHA Structure	1
2	Local Rules	1
2.1	Local Competition Rules	1
2.2	Match Template, Durations and Starting Times.....	1
2.3	Time Keeping for Matches.....	1
2.4	Yellow Card Rule – A Player Penalty System.....	2
2.5	Team Points Scoring for Fixture Matches.....	2
2.6	Late Starting of Fixture Matches.....	2
2.6.1	Determination of Late Starting Fixture Matches – Artificial Surfaces.....	2
2.6.2	Penalty for Late Starting of Fixture Matches	3
2.6.3	Determination of Late Starting Fixture Matches – Grass.....	3
2.6.4	Extenuating Circumstances	3
2.7	Permitted Number of Players	3
2.8	Forfeiture of Matches	3
2.9	Withdrawal of a Team Mid-Season.....	3
2.10	Umpires.....	4
2.11	Ball Attendants	4
2.12	Joint Finals Matches.....	4
2.13	Club Days	4
2.14	Grass Fixture Matches	4
2.15	Minkey and Under 9 Competitions.....	4
2.16	Coaching from the Back Line	4
2.17	Player Substitutions.....	4
2.18	Umpire Examinations	5
2.19	Fixture Matches During State Titles.....	5
2.20	Head Injuries	5
2.21	Goalkeepers.....	5
2.22	Banned Play – ‘Tomahawk’	5
2.23	Veterans Hockey League (VHL).....	5
3	Registration System.....	6
3.1	Registrations	7
3.1.1	Points Cap.....	7
3.1.2	Team Registrations	8
3.1.3	Player Registrations	9
3.1.4	Age Eligibility	9
3.1.5	Player Registration Number.....	10
3.1.6	New Player Registrations	10
3.2	Number of Players Registered	10
3.3	Player List for Matches.....	10
3.4	Players Eligibility For Finals.....	10
3.5	Registered Juniors Playing Seniors.....	11
3.6	Mixed Gender Policy	11
3.7	Playing in a Lower Division / Competition.....	11
3.8	Re-Registration of Players.....	11
3.9	Memorial Cup and President’s Trophy.....	12
3.10	Transfers and Clearances	12
4	Promotion and Relegation.....	12

4.1	Promotion.....	12
4.2	Relegation.....	12
5	Control of Matches.....	12
6	Requirements for Team Sheets and Result Slips	13
6.1	Results.....	13
6.2	Match Records and Team Sheets	13
6.3	Premiership Points Table	14
6.4	Temporary Suspensions	14
6.5	Permanent Suspensions	14
7	B.H.A Best and Fairest Medal Scoring System	14
8	Premiership Final Series, Memorial Cup and Presidents Cup	15
8.1	Playing Surfaces Used.....	15
8.2	Determining Premiership Ladder Placings.....	15
8.3	Minor Premierships	15
8.4	Finals Playoff Procedures.....	15
8.5	Memorial Cup and President’s Trophy.....	16
8.6	Determination of an Outright Winner	16
8.7	Drop-off Rules	16
8.8	Special Events	17
9	Communications	17
9.1	Hockey Information Service and Wet Weather Procedures	17
9.1.1	Wet Weather Information.....	17
9.1.2	Postponement of Matches	17
9.2	Enquires and Bookings of Artificial Surfaces	17
9.3	Communication with the B.H.A Office.....	18
9.4	Courtesy in Communications.....	18
9.5	Player Insurance Claims	18
10	Artificial Surface and Venue Rules	18
11	Registered B.H.A Hockey Club Fields and Venues.....	19
11.1	Numbering and Locations.....	19
12	Using the B.H.A. Match Record Sheets	19
12.1	Prior to the Match.....	19
12.1.1	The Match Details.....	19
12.1.2	The Player Details	20
12.1.3	The Team Officials Details.....	20
12.2	During the Match.....	20
12.2.1	Goals and Offences.....	21
12.2.2	Goal Summary.....	21
12.2.3	Set Play Summary	21
12.2.4	Misconduct and Offence Summary	22
12.3	After the match.....	22
12.3.1	Checking and Signing Summary.....	22
12.4	Completed Sheets.....	23
13	B.H.A. Competition Forms.....	23

1 BHA Structure

1. The Brisbane Hockey Association Inc. competition fixtures are as follows:

COMPETITION NAME	DIVISIONS	NUMBER OF TEAMS
Brisbane Hockey League (BHL)	1, 2, ... etc	Generally 8 with a minimum of 6 per division
Classic Hockey League (CHL)	1, 2, ... etc	Generally 8 with a minimum of 6 per division
Veterans Hockey League (VHL)	1, 2, ... etc	As recommended by the B.H.A. Veterans Committee
Juniors	J1, J2, ... etc U7 to U13	As recommended by the B.H.A Junior Committee

2. There will be a minimum number of matches for each division as determined by the B.H.A. Board.
3. There will only be full rounds in all divisions unless decided otherwise by the B.H.A. Board.
4. The B.H.A. Board reserves the right to grade all teams in any division where it benefits the competition.

2 Local Rules

1. The B.H.A. Board has discretionary powers over these Competition Rules and Requirements with respect to interpretation and application. This document replaces all previous versions of the Competition Rules and Requirements and will remain current until replaced with a newer version.

2.1 Local Competition Rules

1. These local rules shall prevail of any other rules. The order for applying rules is as follows:
 - a. Local Rules;
 - b. International Rules (as per rule book).

2.2 Match Template, Durations and Starting Times

1. The template continues to be a product of ongoing negotiation and agreement between B.H.A., B.W.H.A, and other sporting associations as required. The B.H.A. Board will determine the template.
2. Match Durations are as follows:
 - a. Senior matches should consist of 35-minute halves with a 5-minute half time break.
 - b. Veteran matches should consist of 30-minute halves with a 5-minute half time break.
 - c. Junior matches should consist of 30-minute halves with a 5-minute half time break.

2.3 Time Keeping for Matches

1. Central Timing will be enforced during all matches played at all venues where available.
2. Where matches are timed by technical officers or by means other than the umpires, the matches will be started and re-started by the umpires but the match will end on the siren at the end of the required period of time except in the case of extension of time to allow for the completion of a penalty corner or penalty stroke in which case the match will end on the umpires' whistle.

3. Time off during fixture matches will not be permitted. Time off will be permitted during the Finals' series, Memorial Cup and President's Trophy matches, except where such matches are played as regular fixtures. However, match time may be lost for various reasons such as serious injury or when the playing surface has become unplayable, e.g. excessive water (rain) on the surface, etc.
4. Where players incur a serious injury and cannot be removed from the field for a period greater than 15 minutes then the match shall be abandoned unless otherwise agreed by the team captains. Umpires are required to ensure that all injured players leave the field as quickly as possible.
5. Where the venue manager rules that the playing surface is unplayable and more than 15 minutes of playing time is lost then the match shall be abandoned.
6. Where the team captains and umpires agree that a surface is unplayable for a period in excess of 15 minutes then the match shall be abandoned.
7. The B.H.A. Board shall reschedule abandoned matches.

2.4 Yellow Card Rule – A Player Penalty System

1. In addition to all Senior Competitions this rule also incorporates the junior “J” competition with points accumulated in any of these competitions being cumulative and reciprocal.
2. B.H.A. implements a points system for yellow cards where by each minute that a player is suspended during a match they accumulate one (1) point. All yellow cards issued in a match must be accurately recorded on the team sheets in the Yellow Card column beside the relevant player.

FIH Rules – Umpiring Section 2.3e states:

“It is possible for a player to receive two green or two yellow cards for difference offences during the same match but when an offence for which a card has been awarded is repeated, the same card must not be used again and a more severe penalty must be awarded.”

3. When a player has accumulated twenty (20) points, or more, within a six-week period (matches in which a player has actually participated), a player shall be automatically suspended for eight (8) days, effective at the end of the fixture in which the most recent card was received and the suspension will remain at the B.H.A. Board's discretion. The Club Secretary will immediately inform the B.H.A. General Secretary the player is serving his suspension. Once a suspension has been served, the player may resume playing with a “clean slate”.
4. Failure to inform the B.H.A. General Secretary may mean that further penalties will be imposed by the B.H.A. Board with the proviso that the B.H.A. General Secretary continuously tracks yellow card offences.

2.5 Team Points Scoring for Fixture Matches

1. During the fixture competitions for all divisions, three (3) points will be awarded for a win, one (1) point will be awarded for a draw, zero (0) points will be awarded for a bye and three (3) points and three (3) goals to nil (0) will be awarded for a forfeit.

2.6 Late Starting of Fixture Matches

2.6.1 Determination of Late Starting Fixture Matches – Artificial Surfaces

1. All artificial surface matches must start on time in accordance with the times set down in the fixtures of the Association. Any team or teams not prepared to start on time shall be fined fifty dollars (\$50) by the B.H.A Board. The decision of the Umpires or Technical Bench Officer in

charge of matches shall be final as to whether any team is late. If any team is, in the opinion of the B.H.A Board persistently late, the B.H.A. Board may increase the amount of the fine.

2.6.2 Penalty for Late Starting of Fixture Matches

1. Unless good and sufficient reason for the delay can be shown to the B.H.A Board, then the team prepared to play will be awarded the match as a forfeit.

2.6.3 Determination of Late Starting Fixture Matches – Grass

1. If after a period of fifteen (15) minutes a team does not take the field, forfeiture will be awarded to the team ready to play.

2.6.4 Extenuating Circumstances

1. The B.H.A Board has discretionary powers to consider extenuating circumstances in the case of forfeits.

2.7 Permitted Number of Players

1. Teams may be completed to their full strength of eleven (11) players at any time during the match provided that the names of the players agree with the list handed to the umpire prior to the commencement of the match and provided that no team shall take a field with less than eight (8) players. Up to sixteen (16) players may be used in any fixture match, but only a maximum of eleven (11) players per team is permitted in play, therefore, a maximum of five (5) substitutes is permitted.
2. Any Club found guilty of taking the field with more than eleven (11) players in any team in any match will receive an automatic penalty of the loss of points for that team for that match and a fine of fifty dollars (\$50) in respect of every player so infringing.

2.8 Forfeiture of Matches

1. Any club receiving forfeiture shall be credited with three points and shall be treated as having scored three (3) goals to nil (0). Any team giving forfeiture will be treating as having lost the match three (3) goals to nil (0). In the event of two opposing teams giving forfeiture, the point's score by each team shall be nil (0) and the goals scored shall be nil (0).
2. For the purpose of these rules, a forfeit shall be deemed to have arisen when one team, on the day of play, either fails to appear at the time set down for play, within such time specified in these rules, and without notification that such team intends to forfeit, or appears at the playing ground with less than eight (8) players. In such case the opposed team, before being credited, is to take the field and to comply in all respects with the requirements of these rules as fully as if the opposing team had appeared, PROVIDED HOWEVER that such team shall not be required, when having taken the field, to take any further part in this match.

2.9 Withdrawal of a Team Mid-Season

1. In the event of a Club withdrawing a team during the season, then all matches scheduled for that team shall be deemed null and void.
2. In the event that a complete round/s has/have been played then a new draw shall be made.
3. Where a team is withdrawn after the start of fixtures, the Club withdrawing such team will be liable for any costs in connection with the registration of such team with the B.H.A. and Hockey Queensland.

2.10 Umpires

1. The umpires committee will appoint umpires to matches. It is the Clubs' responsibility for matches in the manner prescribed by the B.H.A. Board. Players who are designated by their Club to umpire a particular match, that are unable to be there must arrange some one else to umpire the match. A Club whose member is unable to carry out the assigned umpiring duties shall be guilty of an infringement of the rules and the relevant Club shall receive an automatic umpiring penalty per offence. Where one Club has supplied an umpire for another Club, the Club that completed the umpiring duty will be awarded an umpiring fee upon applications to the B.H.A. board and the B.H.A. Board approval.
2. If neither the named official umpire nor the backup umpire shows up to perform the umpiring the teams are responsible for the umpiring duty. If only one named or backup umpire is in attendance, the responsibility for the umpiring lies with the team named in the corresponding position, i.e. if the first name umpire does not show up the first named team must cover the umpiring responsibility.

2.11 Ball Attendants

1. During normal fixture matches the use of Ball Attendants will only be permitted if both teams agree.

2.12 Joint Finals Matches

1. To be determined by the BHA Board. The match times and field allocations will be determined by a Joint Committee made up of representatives from B.H.A. and B.W.H.A.

2.13 Club Days

1. Any Club wishing to have a Club Day shall negotiate with the B.H.A. Director of Competitions prior to the creation of the season's fixtures. Grass competition Club Days will be considered where possible.

2.14 Grass Fixture Matches

1. A Central Venue approved by the Board will be utilised for the Senior and Junior Competitions

2.15 Minkey and Under 9 Competitions

1. The Under 7 (Minkey) and Under 9 (Modified) competitions shall be localised wherever possible. The competitions may involve a single club or several clubs. Clubs are to ensure that such competitions adhere to the rules of hockey including the rules and requirements of Brisbane Hockey Association Inc and will at all times be considered as being under the control of B.H.A. Inc. (i.e. Playing venues included in fixture allocations).

2.16 Coaching from the Back Line

1. Coaching from the back line is prohibited for all Senior and Junior Competitions. Penalties will be invoked for breaches of this rule.

2.17 Player Substitutions

1. All player substitutions must be effected from the halfway line. Substitutions during grass matches may be made from either side of the field provided that all players enter and leave from the same side. If a Technical Bench is in operation substitutions will enter and leave from the same side of the field as the Technical Bench.

2.18 Umpire Examinations

1. Players nominated by their clubs must sit and pass an umpiring examination compiled by B.H.A.

2.19 Fixture Matches During State Titles

1. Matches as determined by the B.H.A. Board may be scheduled on the weekend of the State Titles and/or Premier League.

2.20 Head Injuries

1. Where a player has been knocked unconscious ('knocked out') or on the advice of the First Aid Officer that a player not participate any further in the match the injured player:
 - a. Must take no further part in the match in which he was injured;
 - b. Must not take part in any other hockey match on that day, and;
 - c. Must produce a medical certificate from a doctor that clears the player to resume playing.
2. Where a player refuses to leave the field for any of the aforementioned instances the umpires or the relevant officials must order the said player from the field and not resume the match until this has occurred. Where a player continues to refuse to leave the field or continues to disrupt any match the said player will be cited for misconduct.
3. With regard to 2.20.1.c above (mandatory medical certificate) the player's Club Secretary must forward such certificate to the B.H.A. Office before the said player resumes playing whether that be at any level of participation.

2.21 Goalkeepers

1. A team must have a goalkeeper fully protected or wearing a minimum of a helmet for a game to be played.

BHA has not adopted the changes to the FIH rule 2.2. Early in 2007 BHA adopted a position on this rule change as recommended by Hockey Queensland. The recommendation is as follows:

“GOALKEEPING: That the recommendation as follows from Hockey Australia be adopted by Hockey Queensland. Hockey Australia recommends to all state and regional associations that the change to the FIH rules is not adopted for competitions below national championship level – thereby meaning that teams DO have a goal keeper at all times (open fully protected or minimum of a helmet) for a game to be played.”

2.22 Banned Play – ‘Tomahawk’

1. The “tomahawk” method of striking the ball is banned in all B.H.A. divisions and competitions with the exception of the BHL1 and BHL2 divisions where this “skill” is expected of players at representative level. The tomahawk is defined as “a backhand hit with a wind-up, using the edge of the stick.”

2.23 Veterans Hockey League (VHL)

1. The following rules apply exclusively to the Veteran's Hockey League. They have been developed over time in order to account for some of the difficulties involved in the management of a competition for this age group and the fact that it is also exclusively a mid-week competition. These rules are the product of recommendations made by the Brisbane Veteran's Committee to the B.H.A. Board and their subsequent ratification by the B.H.A. Board.
 - a. All players participating in the VHL Competition must be aged 40 or more by the 31st December of the year in which they are participating.
 - b. An umpire's duty may be shared by two players in recognition of the limited time available between matches for players to dress and warm up. Umpires must ensure that all matches commence on time.

- c. Should a team not be able to field a team of twelve (12) players for a match then it is permissible to “borrow” one or more players from another competing team in order for the match to go ahead. In such circumstances a team is only permitted to “borrow” sufficient players in order to obtain a maximum of twelve (12) players participating in the match. Borrowed players cannot be taken from a team in a higher division except where permitted with the consent of the opposing team’s captain.
- d. In circumstances where one or both teams are “borrowing” players for a match the “borrowing” team(s) may not gain a numerical advantage over the opposing team using this process.
- e. Substitution of players injured during a match by the process of “borrowing” a player will only be permitted with the consent of the opposing team’s captain.
- f. Goalkeepers may interchange between teams.
- g. Washed-out matches will be treated as scoreless draw and will not be rescheduled. This is necessary due to the already tight scheduling of the competition and the lack of suitable mid-week timeslots available on artificial surfaces.
- h. For a player to be eligible for the finals' series a player must have played 30% of fixture matches available to that player's team during the season. Should a player not meet this criterion then special approval must be sought in writing from the BHA Board via the Brisbane Veteran's Committee. Matters to be considered might include: player injury, work commitments or transfers, travel, etc. (See also 3.1.4).
A player who meets this requirement may play for another team in a final for a higher division subject to the consent of the Brisbane Veteran’s Committee.

3 Registration System

1. Competing Clubs shall nominate teams for registration with B.H.A. using the “Application for the Registration of Club Teams” Form.
2. Competing Clubs shall nominate their players for registration with B.H.A. using the “Team Registration Form” prior to the commencement of the first fixture date.
3. Players’ names must appear in alphabetical order with the surname first.
4. Competing Clubs shall register eleven (11) players in each senior division for which they have nominated prior to the beginning of the first fixture (per division) with players only then being able to play in divisions upwards.
5. Clubs may apply to the B.H.A. Junior Committee to register less than 11 players in a team below their highest junior division, if they have a shortage of eligible players for that division. Clubs must demonstrate that they will be able to field a team in the competition, under normal competition arrangements, where less than eleven (11) players are to be registered.
6. Where a player is registered in a particular division that same player can play an unlimited number of matches in the next immediate higher division for his Club. If the same player were to play three (3) matches above his next immediate division then the Club will be asked to show cause why he should not be immediately registered in the next division above where he is currently registered. Once this registration promotion has occurred, the Club may not demote the player below his new registered grade.
7. Should a player miss four (4) matches in succession in their registered division then that player will be automatically re-registered in the division below.
8. No A.H.L. player can play below BHL1 (Division One). If a player has been out of competition with a serious injury a written request to the BHA Board to play in a lower grade may be considered.

9. Eligible Veterans (VHL) players wishing to play in other competitions must be dually registered, i.e. they are to be registered in VHL and/or BHL/CHL.
10. At all times the B.H.A. Board shall administer de-registrations and/or re-registrations including players coming back after a lengthy period of injury. Club Secretaries are to use the prescribed form "Player Registration Re/De-registration Form" for this purpose.
11. Infringements of the registration system will result in a fifty-dollar (\$50) fine increasing by fifty dollars (\$50) for each subsequent infringement.

3.1 Registrations

1. A player cannot be registered in any division/competition with more than one Club. The B.H.A. Board may consider a relaxation of this rule, but only under exceptional circumstances, for example, where a player's Club does not have:
 - a. Veterans team; or
 - b. "J" team.

3.1.1 Points Cap

1. All Clubs completing in BHL grades are subject to this system.
2. The points system covers an entire Club, not just Division 1 and 2.
3. All players are subject to this system. There are no exceptions.
4. Once a Club exceeds the points cap it may not register any additional points scoring players until the Club is once again under the cap. The club may register as many players without points as it desires.
5. Any player who was registered with a club for the previous season may remain with that club even if their inclusion, due to improved representative status, results in the club exceeding their cap. However, the Club will still be subject to rule 3.1.1 - 4.
6. The following categories of players can received discounted points:
 - a. A player who has been with the senior Club since at least Under 13 attracts zero points;
 - b. A player who joined a Club as a junior but after Under 13 attracts 50% of the assigned points;
 - c. A player who has nominated for selection for Brisbane and is not selected in any Premier League or Open team may play for another association at the Open level and attract zero points.
 - d. A Kookaburra player who will play less than the games required to qualify to participate in finals may receive a 50% points discount. Should the player meet the finals qualifying requirement he will be subject to full points. The points weighting must be advised by the club prior to season commencement.
 - e. Where a player has not made himself unavailable for selection for Blades and is not selected in that team then he may be selected for another NHL team and not receive points for that selection. That player will receive points to the representative level achieved in Qld.
7. Junior registered players that attract points are included in a club's total even if they are not registered in a senior team as they may be utilised by senior teams on a temporary basis.
8. Players attract the points associated with the highest status level played for the previous season. The previous season is defined as being completed as at 31st December the previous year.

9. No player selected in Brisbane Premier League 2 or Brisbane Open shall be allocated additional points should they be promoted from those teams due to injury or illness of other players.
10. Overseas and Interstate player points are allocated at the discretion of the Board after considering a recommendation from the "Cap Committee". Representative levels from other States are matched to the equivalent Queensland level. An appeal may be lodged with the Cap Committee if it is considered that the allocation is incorrect.
11. All new players to Brisbane must have a 'Player Status Form' signed by the player and their previous Association confirming their Representative Status.
12. Club player lists must be provided to the Association no less than 4 weeks prior to the start of the season. The association will provide a "points total" to the club to ensure that both the Association and the club are clear on the club's current cap status.
13. With each registration / re-registration / de-registration the association will issue an updated "points total" to the club.
14. In the case of Joint Ventures, the total points shall be deemed as the combined total of all feeder clubs. For example, the total points for United Hockey will be the combined totals of Kedron Wavell Services and South West United Hockey Clubs.
15. A player may be included in a club's registrations, even if the club currently exceeds the points cap, should he meet the following criteria. His mother, father, brother or sister has played for the club for a minimum of 5 years. The player will retain the points allocated to him and the club will take those points into account when considering future players.
16. The following lists the points awarded to each representative status
 - a. National Opens Player – 100 points
 - b. National Under 21 Player – 85 points
 - c. Australian Hockey League Player – 75 points
 - d. State Under 21 Player – 60 points
 - e. National Country Player – 50 points
 - f. National Under 18 Player – 45 points
 - g. Premier League 1 Player (refers to an associations top premier league team) – 45 points
 - h. Premier League 2 Player (refers to an associations second premier league team) – 35 points
 - i. State Under 18 Player – 35 points
 - j. State Country Player – 25 points
 - k. RTP Scholarship Holder – 25 points
 - l. Association Opens Player – Non-Brisbane – 20 points
 - m. Association Opens Player – Brisbane – 0 points

CLARIFICATION – To add clarification to the rules, the implementation of these rules are that the club playing roster at season commencement should indicate all players from the previous year who may be playing in the upcoming season. Those players that are not included in that official playing roster lodged with BHA prior to season commencement are therefore not considered to be playing for that club in the current season. If the club signs on new point scoring players, then those existing players not on the roster that may return after season commencement, will be treated as new players and therefore need to fit under the points cap.

3.1.2 Team Registrations

1. Competing Clubs shall nominate teams by division for registration with B.H.A. using the "Application for the Registration of Club Teams" Form. Until these forms are received from all clubs the creation of the fixture draw cannot begin. Therefore, the B.H.A. Board will decide a suitable closing date for the submission of this form.

2. The Junior Committee may appoint a Grading Committee to determine the composition of junior divisions. The Grading Committee shall consist of a minimum of 3 persons appointed by the Junior Committee with one member being the BHA Coaching Development Manager.
3. Where the composition of a division is to be determined by the Grading Committee, the following process shall be used:
 - a. Teams shall initially be graded (for example - J1, J2 or J3) within the division, based on –
 - i. The clubs requested grading; and
 - ii. The Grading Committee's initial assessment.
 - b. The teams in each grade in the division shall play one round of fixtures, a grading round, as determined by the B.H.A. Junior Committee.
 - c. At the conclusion of the grading round the composition of the division shall be confirmed or altered by the Junior Committee on the recommendation of the Grading Committee.
 - d. Games played during the grading round shall count for points and goal balance as follows –
 - i. If the composition of the division is unchanged at the conclusion of the grading round, points and goal balance shall stand.
 - ii. Where the composition of the division is altered at the conclusion of the grading round, points and goal balance for all teams in the division will be reset to zero and commence with the first scheduled fixture following the grading round.
4. Where a club has more than one team in a division, each team shall be considered a separate team and players can only play in their registered team in that division.

3.1.3 Player Registrations

1. Each individual player must complete, sign and lodge with their club the prescribed "Member Registration Form" or similar. Registration details shall include the players full name, address, telephone number and date of birth, together details of a clearance where relevant and dual registration details declared, i.e. primary and secondary registrations as relevant. Once the forms have been completed and signed, Club Secretaries are to then forward copies to the BHA Office.
2. In addition, competing Clubs shall nominate their players for registration by division (as listed above) with B.H.A. using the "Team Registration Form" prior to the commencement of the start of the first fixture. This form is used to declare to B.H.A. the registered division of each player. All fields on this form are mandatory. An electronic version (MSWord format) of this form is available for download from the B.H.A. Website for electronic submission.

3.1.4 Age Eligibility

1. For grades where age eligibility is considered, is determined as at 1 January of each year. Players must be under the maximum age for a division as at 1 January. Players eligible to be registered in "Age" graded divisions (Minkey – U/13) shall not be older than the maximum age for that division during the year of competition (i.e.: players who will be under or turn 13 during the current calendar year are eligible to be registered in the U/13 division and likewise for the other "Age" graded divisions).
2. Players eligible to be registered in 'J' division shall be over 13 (i.e.: turning 14) and under 17 during the year of competition.
 - a. Players over 13 and under 14 (i.e.: turning 14) during the year of competition shall be eligible to be registered or play in 'J1' division, under the following conditions:
 - i. with written permission from their parent(s)/legal guardian, and club; and
 - ii. on application to the B.H.A. Junior Committee (for registration).

- b. Players eligible for the under 13 division during the year of competition shall be eligible to play in 'J' divisions, under the following conditions:
 - i. with written permission from their parent(s)/legal guardian, and club; and
 - ii. on application to the BHA Junior Committee (for eligibility).
3. Players eligible for the under 11 division during the year of competition shall not be eligible to be registered or play in 'J' divisions.

3.1.5 Player Registration Number

1. Each registered player is to be issued with a player registration number by his club. The B.H.A. General Committee will stipulate the prescribed format of such numbers.

3.1.6 New Player Registrations

1. No player may participate in any match unless such player is officially registered with the Association. However, following the playing of the first fixture of a season, Club Secretaries are to use the prescribed "Player Registration Re/De-registration Form" for this purpose in lieu of using the "Team Registration Form".

3.2 Number of Players Registered

1. A Club with a single team in the B.H.A. competition structure must have sixteen (16) registered players. A minimum of eleven (11) players per team should be otherwise registered in all senior competitions and junior competitions from the "J" divisions through to the Under 11 Division. The B.H.A. Board upon application may consider variations to these requirements.

3.3 Player List for Matches

1. Before the commencement of any match, the Captain/Manager of each team will hand to the umpire or technical bench a list of the players in the team, as prescribed by the B.H.A. Board. No match can proceed until the umpires or technical bench receives such team lists. Where a central control (technical bench) is in operation the prescribed sheet will be handed to the person in charge of the central control. At artificial surface venues only the people named on the prescribed sheet (maximum of nineteen) will be permitted in the dugout at any time.
2. Should any team fail to submit such a list to the umpire or officer in charge of the central control, the same shall be recorded and such Club shall be liable to a fine of no less than twenty-five dollars (\$25) for the first offence, increasing to fifty dollars (\$50) for the next offence, and if any further offences occur, loss of points may occur as per discretion of the B.H.A. Board.

3.4 Players Eligibility For Finals

1. A player must have played six (6) fixture matches in that division or competition in which his club has registered him for that season (where by one (1) week equals one (1) fixture match – unless a double header is played).
2. A player who has played at least six (6) fixture matches in a different division, but less than six (6) fixture matches in the division he is registered, shall be eligible to play only in the division where he has played his six (6) fixture matches (where by one (1) week equals one (1) fixture match – unless a double header is played).
3. Players registered in a junior division who also play seniors must play 50% of the scheduled junior fixture games to be eligible to play in the finals on the junior competition.
4. Any player who has played the required number of fixture matches to qualify for semi-finals and finals in a division may play in any higher division.

5. The B.H.A. Board may consider special cases in relation to the eligibility of players to play in semi-finals and finals of any division. The club requesting special consideration of the eligibility of the player must provide substantial reasons. All reasons must be supported by documentary evidence.

3.5 Registered Juniors Playing Seniors

1. A junior may play in senior matches in any Division but the letters "(JNR)" must appear beside the players name on the Team Card/Sheet.
2. Any junior who has played more than six (6) games in BHL fixtures must be registered in a BHL division and fall under the current BHA registration rules.
3. To be eligible to play seniors a player must be 14 years old (as at 1st January). There will be no exceptions to this rule.
4. Junior Players 14 years to 17 years (as at 1st January) are not permitted to play in senior division unless Parental permission is given in writing to the Club of which he is a member. A copy must also be lodged with BHA.
5. Junior Players 14 years to 17 years (as at 1st January) can only compete in two (2) senior fixture matches per weekend.

3.6 Mixed Gender Policy

1. BHA follows the Hockey Queensland Mixed Gender Policy (derived from the Australian Sports Commission recommendations) which states:

"Mixed Gender Competitions can occur if necessary, for players 12 years and under. Players over the age of 12 years of age must only play in their own gender competition."

To clarify this, players turning 12 years of age during a competition year, may participate in BHA fixtures for that year. However, as per Hockey Queensland's policies, they are not permitted to compete in State Championships in that year.

3.7 Playing in a Lower Division / Competition

1. No player may play in a Competition/Division lower than that in which that player is registered.
2. For the purposes of this rule older 'Age' graded divisions are higher, followed by the 'J' divisions, with 'J1' being the highest B.H.A. Junior division.

3.8 Re-Registration of Players

1. If the necessary re-registration form for players are not submitted by the required time the team may lose points for the match in which the change took place. The deadline (minimum) for any re-registration for any match, including mid-week matches, is twenty-four (24) hours prior to the playing of the fixture.
2. Re-registration of players from higher to lower divisions will not be accepted after the commencement of the final six (6) fixture games.
3. No player who, or belonging to a team which, has been suspended or disqualified or which has been disbanded, shall be permitted to play in another team without first obtaining the sanction of the B.H.A. Board and paying the Association a proportion on a per capita basis of fees due by the Club of which he was a member as determined by B.H.A. Board.

3.9 Memorial Cup and President's Trophy

1. Where possible the preferred option is to run these in conjunction with B.W.H.A. and Junior fixtures.
2. The eligibility criteria will be determined by the B.H.A. Board in the years when these matches are held independent of the competition fixtures.

3.10 Transfers and Clearances

1. Clearances from the previous Club are required whenever a player registers with a new Club. It is the responsibility of the individual Clubs to exchange Clearances. However, the B.H.A. Board may require the Club to submit to the Association a clearance from any previous Hockey Club of which the nominee has been a member, stating that the nominee has no outstanding financial obligations to that club. If such a clearance is not forthcoming, the Board may prohibit that player from competing in B.H.A. competitions.
2. If any Hockey Club lodges with the Association a claim setting forth any outstanding financial obligation that a member of the Association has to that Club, the B.H.A. Board may prohibit that member from competing in any competition organised by the Association for such time as it sees fit; provided that such prohibition shall be lifted upon receipt of a clearance from the Club by which the claim has been lodged.
3. Notice of prohibition shall be given in writing by the General Secretary of the Association to the Secretary of the competing Club that nominated the member is requesting registration with. The prohibition may not be applied retrospectively prior to the start of the current season.
4. Clearances should be sought to avoid the possible loss of competition points.

4 Promotion and Relegation

4.1 Promotion

1. Eligibility for promotion is automatic for any Club team into the next highest division where that team has won the minor premiership and won the premiership, and, where that Club has no team in the next highest division. Such promotion will not apply if the Board or General Committee concludes it to be detrimental to the competition.
2. Any Club team winning either the minor premiership or premiership will upon request, be automatically eligible to be promoted to the next highest division, but only if that team's Club does not already have a team in the next highest division. Such promotion will not apply if the B.H.A. Board or General Committee concludes it to be detrimental to the competition.
3. Notwithstanding paragraphs (a) and (b) above any Club team can be promoted or relegated into any division but only at the discretion of the General Committee.

4.2 Relegation

1. Where a team has been promoted into a higher division, the B.H.A. Board or General Committee may decide to relegate the team that finished last in that higher division.
2. Upon recommendation from the B.H.A. Board, the General Committee may decide to relegate a team for the best interests of the competition.

5 Control of Matches

1. The Board will endeavour to appoint Technical Bench Officers wherever possible. The relevant duties are as follows:

- a. Ensure that all yellow cards are registered on the prescribed team card/sheet.
 - b. Ensure that all match cards/sheets are returned to the General Secretary of the B.H.A.
 - c. Operate the scoreboard, where relevant.
 - d. Ensure that players and officials adhere to all artificial surface rules.
 - e. Ensure that player behaviour is appropriate for the circumstances.
 - f. Report to the Board in writing, any instances of misconduct, not reported by an umpire, using the prescribed "Incident Report" form.
2. Each team playing on an artificial surface shall provide one person to assist either the Technical Bench officer/s or the B.H.A. official in charge of the match.

6 Requirements for Team Sheets and Result Slips

6.1 Results

1. At all grass venues it is the responsibility of the canteen convenor to communicate the results of fixtures played at that venue to the person appointed by the B.H.A. Board no later than 6.00 pm on the day the fixtures are played.
2. At all centrally controlled venues it is the responsibility of the person in charge of the Technical Bench to communicate the results of fixtures played at that venue to the person appointed by the B.H.A. Board on the day the fixtures are played.

6.2 Match Records and Team Sheets

1. Match Records must be presented to the Umpire/Technical Bench, prior to a fixture match. Team sheets must be correctly filled in as follows:
 - a. Surname first, followed by full Given Name;
 - b. Registered Junior players playing in all senior matches must have the letters 'JNR' in brackets entered beside their name;
 - c. Team Captains must have the letter 'C' in brackets inserted beside their name;
 - d. For BHL divisions each player's individual shirt number must appear on the team card;
 - e. The players' registration numbers must appear in the designated space on the team sheet (or card) when such a system is in place.
2. Team sheets are in triplicate with the top (original) leaf to be submitted to the B.H.A. Office, the blue copy returned to the Club administrators and the green copy retained in the book for the Club's records.
3. CHL team sheets (originals) from Saturday fixture matches must be in the hands of the B.H.A. General Secretary by 5pm the next Monday. CHL team sheets (originals) from Sunday fixture matches must be in the hands of the B.H.A. General Secretary by 5pm the following Tuesday. It remains the responsibility of the host Club to ensure that these deadlines are met. At the discretion of the B.H.A. Board a fine of one hundred dollars (\$100) for the first offence with subsequent increases of fifty dollars (\$50) per offence will be incurred by the host Club if the above practice is not followed.
4. For the BHL and VHL competitions it is the responsibility of the Technical Bench personnel to ensure that the team sheets (originals) are returned to the B.H.A. General Secretary within twenty-four (24) hours of the match being played. At the State Hockey Centre a set of clearly marked pigeonholes is provided immediately inside of the State Hockey Centre Reception (to the right) for this purpose.
5. Captains should check that the scores and other relevant information have been correctly recorded before signing at the completion of the match. Team cards and sheets are considered by the Association as official correspondence. All team cards and sheets must be legible in all respects. Failure to comply with this may result in a fine of one hundred dollars (\$100).

6. In order to receive prescribed payment for the umpiring of a match, Official Umpires shall correctly and legibly record their ID number, print their name and sign each sheet. Failure to comply will lead to non-payment.

6.3 Premiership Points Table

1. The Board will publish on a regular basis Premiership Points Tables for each competition/division.

6.4 Temporary Suspensions

1. Temporary suspensions (yellow cards) must be accurately recorded on the team sheets in all divisions. The length of each such suspension must also be accurately recorded, i.e. 5 or 10 minutes.

6.5 Permanent Suspensions

1. For grass fixture matches the relevant umpire/s must report such suspensions before 6:00 pm that evening to the Association's answering service or by direct communication with the B.H.A. General Secretary.
2. For artificial surface fixture matches the person in charge of the Technical Bench must report such suspensions that evening to the Association's answering service or by direct communication with the B.H.A. General Secretary. In the absence of a Technical Bench the relevant umpire/s are responsible for reporting such suspensions to the Association's answering service as above.
3. The telephone number for the Association's answering service is 3899 4399. Failure to comply with either of the above may result in the levying of penalties by the B.H.A. Board.
4. In either case the player and umpire involved will be expected to attend a judiciary hearing on the next Monday evening (unless a Public Holiday) immediately following the incident, at the B.H.A. Office (SHC) at 6:30 pm or any other time or place as determined by the B.H.A. Board unless otherwise instructed by the B.H.A. General Secretary.

7 B.H.A Best and Fairest Medal Scoring System

1. The award for the "best and fairest" player in the BHL 1 competition is currently known as the "B.H.A. Best and Fairest Medal". Points are allocated for each fixture match on a 3, 2 and 1 basis. The player with the most points at the end of the season is the winner. An award is also made to the player receiving the most points for each club.
2. The B.H.A. Board will decide the method/system to be used for awarding the best and fairest points.
3. A player receiving a red card and found guilty of an offence resulting in a fine or suspension shall be disqualified from winning the medal.
4. No draws are permitted and players receiving equal points at the end shall be separated by count back. The player receiving the most three point awards shall be declared the winner. If the count is still equal then the player receiving the most two point awards shall be declared the winner. If the count is still equal then the player receiving the lesser number of yellow cards shall be declared the winner. Final determination of the winner if necessary shall be made by the senior selection panel and by a cut of cards or any other method approved by the B.H.A. Board for individual team winners.

8 Premiership Final Series, Memorial Cup and Presidents Cup

8.1 Playing Surfaces Used

1. All Senior and Veterans Semi-finals, Preliminary Finals, Grand Finals, Memorial Cup and President's Trophy Finals matches shall be played on the same surfaces used for fixture matches unless otherwise decreed by the B.H.A. Board. However, where division one junior teams play the majority of their scheduled fixture matches on artificial surface they shall play their semi-final and finals series on the artificial surface.

8.2 Determining Premiership Ladder Placings

1. After completion of all competition (fixture) matches, team placings on the premiership ladder shall be determined for each division. Premiership points awarded throughout the season are totalled and the premiership ladder is arranged in descending order, i.e. the team with the most premiership points appears at the top of the premiership ladder. In the event of equal points, the team with the greater goal difference shall be placed higher on the premiership ladder.

8.3 Minor Premiership

1. On completion of the premiership rounds the team leading the premiership ladder shall be declared Minor Premiers.

8.4 Finals Playoff Procedures

1. For a division comprising of nine (9) teams or less the finals series shall be contested by the teams finishing 1st, 2nd, 3rd & 4th on the premiership ladder. For a competition/division comprising ten (10) teams or more the finals series shall be contested by the teams finishing 1st, 2nd, 3rd, 4th & 5th on the premiership ladder. Other play-off procedures may be considered by the B.H.A. Board from time to time. The play-off procedures are detailed in Figures 1 & 2.

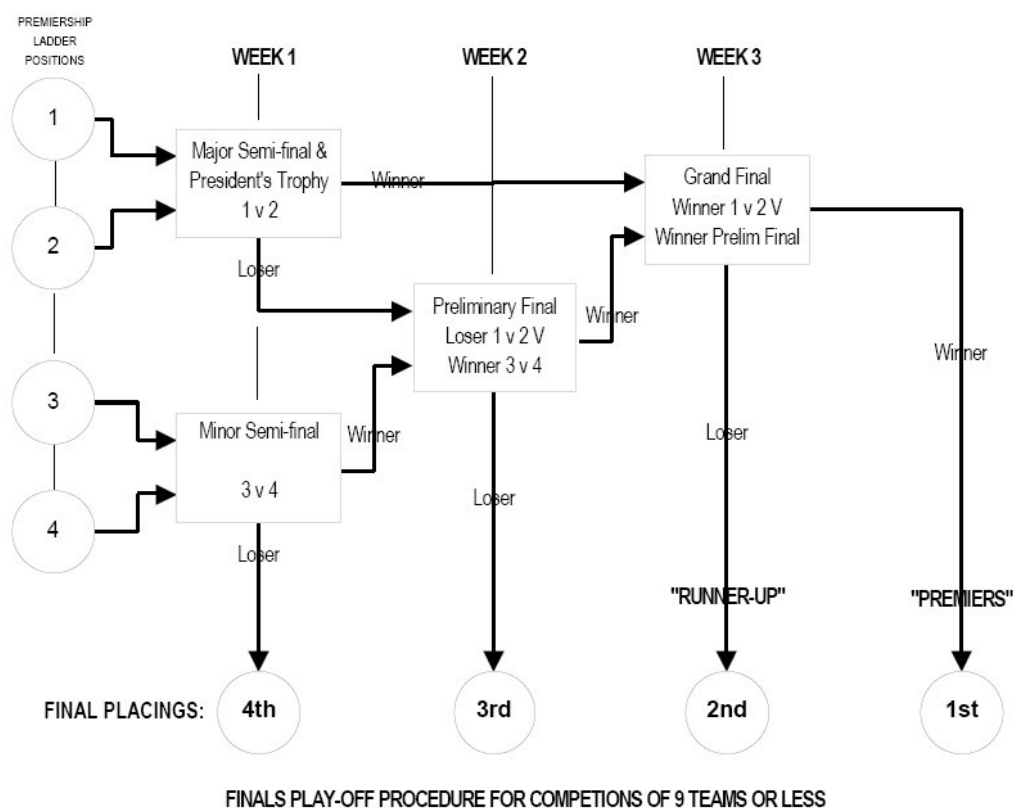

Figure 1

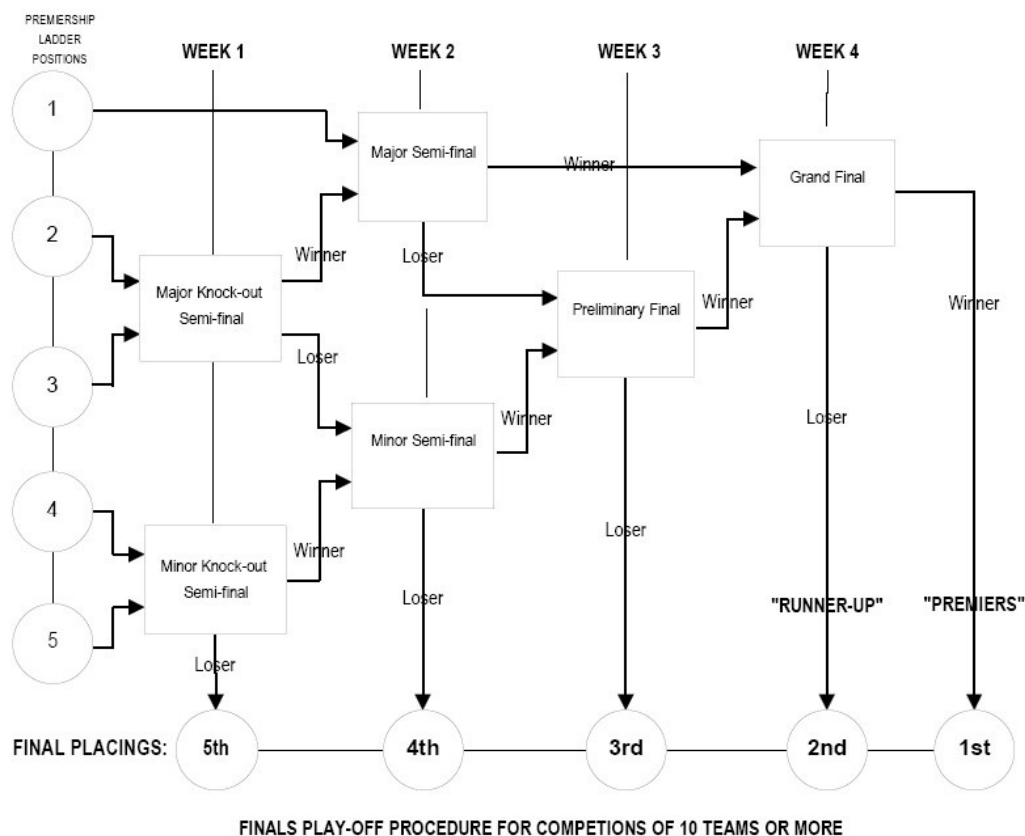

Figure 2

8.5 Memorial Cup and President's Trophy

1. Memorial Cup and President's Trophy shall be conducted under the conditions as determined by the B.H.A. Board. In general, they shall be contested by two teams leading on points in their respective divisions at the conclusion of the first round of Premier'ship fixtures in the case of the Memorial Cup and at the conclusion of the second round of the Premier'ship fixtures in the case of the President's Trophy or a special competition as determined by the B.H.A. Board.

8.6 Determination of an Outright Winner

1. When the scores are equal at the conclusion of normal playing time, an outright winner shall be determined by extending the duration of the match in accordance with the rules for "Drop-off" as follows.

8.7 Drop-off Rules

1. At the conclusion of normal time there will be five (5) minutes rest during which time the captains will toss a coin to decide ends.
2. For the first five (5) minute period of "golden goal extra time", each Team shall nominate nine (9) players, including a goalkeeper, to take the field.
3. After the first five (5) minute period, the teams shall remove two (2) players and immediately change ends for re-commencement.
4. For the second five (5) minute period of "golden goal extra time", only seven players from each Team, including the goalkeeper, shall take the field.

5. After the second five (5) minute period, teams shall remove two (2) players and immediately change ends for re-commencement.
6. For the third period of "golden goal extra time", five (5) minutes will be played and only five (5) players from each Team, including the goalkeeper, shall take the field.
7. Normal interchange rules will apply during extra time.
8. "Golden goal" means the match will conclude once the first goal has been scored.
9. If the scores are still equal at the end of "Drop-off" then a Penalty Stroke Competition will follow for the determination of an outright winner.

8.8 Special Events

1. The B.H.A. Board shall determine all of the requirements for special events.

9 Communications

9.1 Hockey Information Service and Wet Weather Procedures

1. The Hockey Information Service telephone number is 1900 962 018. The purpose of this recorded service is to provide important information from time to time regarding wet weather, special events etc. While B.H.A. is the subscriber to this service, its use has been extended to incorporate other Brisbane Hockey entities, including the State Hockey Centre, Brisbane Women's Hockey Association and Shawspartz. A voice menu system guides callers to the appropriate recorded message.

9.1.1 Wet Weather Information

1. Should there be any doubt in relation to field conditions due to inclement weather the following procedure will occur:
 - a. The Grounds Committee (and/or the B.H.A. Board) inspects the necessary fields and makes the appropriate decision. In the case of commercially operated facilities, a representative of the facility makes such decisions.
 - b. This information is then passed on to the person authorised to operate the B.H.A. Information Service. This person then updates the B.H.A. Information Service with this information.
 - c. Players, parents and officials can then call the Hockey Information Service on 1900 962 018 at their convenience to receive up to date information on field conditions. During wet weather all players and officials are encouraged to ring the Hockey Information Service prior to their departure for matches to ascertain if venues are playable.

9.1.2 Postponement of Matches

1. In the event of the grounds being determined as unfit for play the matches will be postponed to a future date to be arranged by the B.H.A. Board. If a suitable date is not available the B.H.A. Board will decide what actions to take.
2. When a B.H.A. Official is not available, the Captains shall endeavour to decide a ground's suitability for play and in the event of disagreement the umpires shall decide.

9.2 Enquires and Bookings of Artificial Surfaces

1. All Clubs and their members are to book artificial surface time for training purposes directly with the respective venue operators only. Clubs will be billed directly by the venue operator.

9.3 Communication with the B.H.A Office

1. The telephone number of the B.H.A. Office is 3899 4399. The telephones at the office are generally manned between 9.00am and 5.00pm week days. However, members are asked to limit calls to the office, to the hours between 1.00pm and 5.00pm. This will allow the staff in the office to complete the daily tasks with minimal interruptions. Requests for information such as fixture/training times should be addressed to the individual's Club Secretary and not to the B.H.A. Office. Should your call not be answered when telephoning the B.H.A. Office, please leave a meaningful message on the answering machine. Include your name, contact number and the nature of your enquiry. Your call will be attended to as soon as possible. Alternative methods of communicating with the BHA Office are:
 - a. by facsimile (fax): 3399 9825
 - b. mail: The Secretary
Brisbane Hockey Association Inc
PO Box 503
MORNINGSIDE QLD 4170
 - c. email: secretary@bha.org.au
2. Further information such as fixtures, results, progressive points tables, venue locations, Club contacts, etc can also be found on the Internet at: www.bha.org.au This information is maintained by the B.H.A. General Secretary.

9.4 Courtesy in Communications

1. Most people who are involved with Hockey, do so for the love of the sport. Most are volunteers. While there will be disagreements between people from time to time and the occasional mistake made, generally everyone is well intentioned. Most people can accept constructive criticism, however abusive verbal attacks are not acceptable, either on or off the field. *Think before you let fly!*
2. Most players and administrators alike are employed in full-time or part-time employment. Many employers do not take kindly to continual interruptions of an employee. Limit calls to members' work places as much as possible. Where a person has indicated that they do not wish to be contacted at work, by telephone, fax and/or email, then please comply.

9.5 Player Insurance Claims

1. Should it be necessary for you to lodge a claim for injury, please contact the insurer, OAMPS LASER, by telephoning 3367 5160 to request the appropriate (hockey) form. Alternatively the (hockey) claim form may be downloaded from the OAMPS LASER Website:
www.ieasport.com.au
Links to this form and other important information can also be found on the BHA Website (www.bha.org.au). Do not ring the B.H.A. Office! Player Insurance is arranged by Hockey Queensland, telephone: 3399 6577.

10 Artificial Surface and Venue Rules

1. The rules governing the use of the artificial surfaces for matches, training or as supporters is contained in the respective User Manuals as prescribed by the relevant venue operators. Copies of the rules for the State Hockey Centre are available from the venue operator, Hockey Queensland (www.hockeyqld.com.au), telephone 3399 6577. Information and rules governing the usage of Burringbar Park Facility and Shaw Park may be obtained from ShawSportz, telephone 3260 5020.

11 Registered B.H.A Hockey Club Fields and Venues

11.1 Numbering and Locations

1. The current list of BHA registered fields can be found on the Internet at www.bha.org.au

12 Using the B.H.A. Match Record Sheets

1. B.H.A. uses Team & Match Record Books to record the outcomes of matches. They are used in all Senior Divisions and most Junior Divisions.
2. B.H.A. will supply one book per registered team prior to the commencement of the season. The aim of the following is to explain the correct way to use and fill in the Team & Match Record sheets. While filling in the sheets is mostly straight forward and in the main fairly obvious this document seeks to establish practical Association-wide standards. A copy of this section is generally included in each book.

12.1 Prior to the Match

1. There are several sections of the sheet that must be filled in prior to the match. These are:
 - a. Match Details
 - b. Player Details
 - c. Team Officials Details
2. Prior to the commencement of centrally controlled (artificial surface) matches, and in a timely manner, the Team & Match Record Book is to be handed over to the Technical Bench. The Technical Bench will be responsible for the recording of goals scored, a summary of set plays and the details of offences.
3. In the case of other matches that are not centrally controlled (grass), each participating team should nominate a person on the sideline to record details of the match. In the absence of such persons the books will be handed to the match umpires who will locate the books in a safe place after checking the details on the sheets prior to the commencement of the match. In such circumstances, the umpires will be required to keep the scores and to record the scores in the books at half time and full time. Further, in these circumstances, it is not a requirement that umpires record 'Set Plays' however they must record the details of 'Offences' (if any) in full.

12.1.1 The Match Details

Team:	Division:	Date: / /
Opposition:	Venue/Field No.:	Time:

The diagram illustrates the match details section of the record sheet with callouts for the following fields:

- Name of your Club or Team** (points to the Team field)
- Division eg. BHL3** (points to the Division field)
- Date of the Match** (points to the Date field)
- Name of the opposing Club or Team** (points to the Opposition field)
- Start Time of the Match** (points to the Time field)
- Field Name or Number Eg. SHC1, BUR, SHAW5** (points to the Venue/Field No. field)

12.1.2 The Player Details

	Player's Registered Division	Start Team ✓	Time Sub On (min)	Shirt No	USE BLOCK LETTERS ONLY		
					Surname	First Name	(Jnr) (C)
1							
2							
3							

Grade the player is currently registered

Enter a tick beside each of the 11 players starting the match

The time that players who did not start the match, joined the match

Shirt No's must be unique

Surname followed by first name of each player and team official

Use bracketed (C) to indicate the team captain
Use bracketed (Jnr) to indicate junior players

12.1.3 The Team Officials Details

16				
17			Team Coach:	
18			Team Manager:	
19			Assistant Coach:	

Enter the name of the team coach (if any)

Enter the name of the team manager (if any)

Enter the name of the Team Assistant Coach (if any)

12.2 During the Match

1. Only the people named on the sheet will be permitted in the dugout at any time as per the BHA Competition Rules and Requirements. When recording the 'minute' that an event occurred (goal scored, card received, etc) the following convention applies:
 - a. Matches are 35 minutes each way with a 5 minute break, therefore the first minute of the match is recorded as '1'
 - b. The first minute of the second half is recorded as '41'
 - c. The last minute of the match is recorded as '75'.

12.2.1 Goals and Offences

1. In each of these columns goals and offences are indicated by using the digit '1' for each occurrence for each player (or official).

Goals	Offences (Cards)		
	G <	Y ;	R

Record the per player goals (if any)

Record the per player and per official card (if any) that have been received for offences

12.2.2 Goal Summary

1. Each goal scored is summarised in this section. It is a compulsory requirement for centrally controlled matches that these details are recorded. They should be recorded during the match.

Goal Summary					
Plyr No	Min	Type	Plyr No	Min	Type

The scorer's shirt number is recorded here

The type of goal is recorded here
Eg. FG = Field Goal
PC = Penalty Corner
PS = Penalty Stroke

The minute when the goal was scored is recorded here

12.2.3 Set Play Summary

1. Set Plays are Penalty Corners and Penalty Strokes. These should be recorded during centrally controlled matches by the Technical Bench. In each of the appropriate areas Penalty Corners and Penalty Strokes are indicated by using the digit '1' for each occurrence.

Set Play Summary	
Penalty Corners	Strokes
1 st Half	
2 nd Half	

12.2.4 Misconduct and Offence Summary

- Where possible offences should be summarised during the course of the match. However it will be necessary on some occasions for the Technical Bench to query the Umpire at half time or full time regarding the nature of some offences.

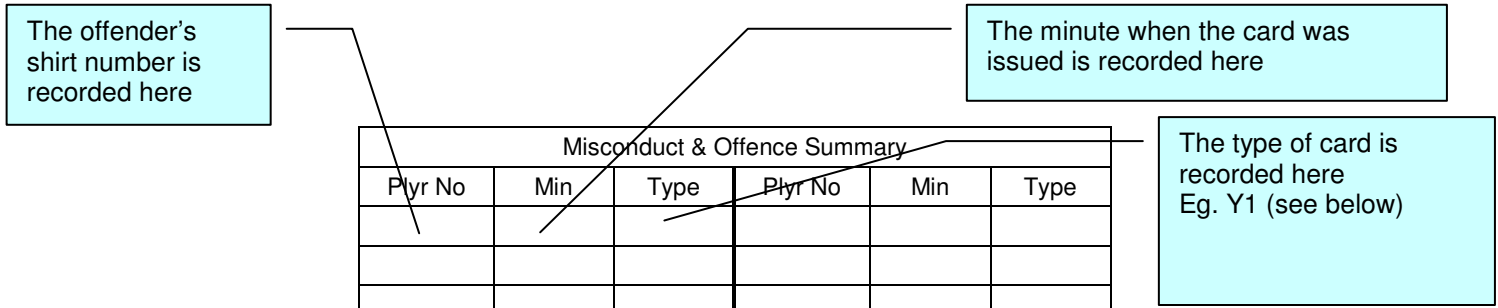

Misconduct & Offence Types

Yellow Card: Y1 – Bad Tackling; Y2 – Dissent; Y3 – Deliberate Breach; Y4 – Swearing; Y5 – Other.....
 Red Card: R1 – Deliberate dangerous play; R2 – Striking Opponent; R3 – Dissent/Abuse; R4 – Other.....

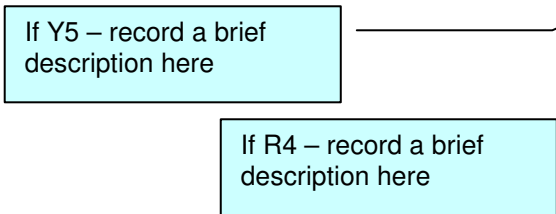

12.3 After the match

12.3.1 Checking and Signing Summary

- It is the responsibility of each of the captains of the opposing teams to check that the details of the match have been correctly recorded on both teams' sheets. Once satisfied each captain is to sign in the spaces provided on both teams' sheets.
- The match umpires are also required to check that the details of the match have been correctly recorded on both teams' sheets. Once the umpires are satisfied with the details they will each record legibly their name, umpire number and signature in the spaces provided. These details will be used as the basis for the payment of umpires. Umpires must also each indicate their 'Type' with a tick, i.e. whether they are Official, Listed Back-up, or Stand-in.
- Official umpires are those with official qualifications and will have generally been assigned to the match by the Brisbane Hockey Umpires Association. Listed Back-up umpires are those who have umpired the match on behalf of the club listed to do the match as per the B.H.A. Fixture Draw. Stand-in umpires are those called upon to 'stand-in' when neither an Official nor the Listed Back-up umpires have umpired the match. However, if by mutual agreement, a person agrees to stand-in on behalf of a listed club then the Listed Back-up box should be ticked. Generally, when a completed sheet is received in the B.H.A. Office with the Stand-in box ticked it means that the listed club on the B.H.A. Fixture Draw shall receive an 'automatic penalty'. (Refer Rule 2.11)
- The attending First Aid Officer is to record their name, their starting and finishing times and their signature in the spaces provided. In the case where they are attending to matches on more than one field at the same time (e.g. grass venues) the First Aid Officer is required to sign at least one of the Team & Match Record sheets for that timeslot. Failure to do so may result in the non-payment of the particular First Aid Officer concerned.

5. Finally, at all centrally controlled matches (e.g. artificial surfaces), the Technical Officers will also check over the sheets of both teams. Once satisfied they will record their name and their signature in the spaces provided on both teams' sheets.
6. Once completed and signed it is an offence for any further alterations to be made to the sheets.

12.4 Completed Sheets

1. Once the sheets have been completed, checked and signed as described, the "original" (white) copy is removed from each team's book while the carbon (coloured) copy is retained in the books for the teams' and the clubs' records. The "original" copies must be dealt with as follows:
 - a. At centrally controlled venues it is the responsibility of the Tech Officer to see that the "originals" from the match are returned to the venue office immediately following the match. Should there not be a Tech Officer then this becomes the responsibility of the match umpires.
 - b. At other venues (grass) it is the responsibility of the match umpires to see that the "originals" are returned to the venue office or canteen. However, should this not be possible (e.g. canteen closed) then it becomes the responsibility of the match umpires to see that the "originals" are returned to the BHA Office by way of a safe and secure manner as soon as is possible. The postal address of BHA Inc is PO Box 503, MORNINGSIDE Q 4170

13 B.H.A. Competition Forms

1. The current list of BHA forms can be found on the Internet at www.bha.org.au