

Brisbane Hockey Association Inc



*Competition Rules
&
Requirements
2004*

Table of Contents

1 BHA FIXTURE STRUCTURE FOR 2004.....	4
2 LOCAL RULES.....	4
2.1 Local Competition Rules.....	4
2.2 Penalty Corners.....	4
2.3 Template & Starting Times for Matches on Artificial Surfaces.....	4
2.4 Time Keeping for Matches on Artificial Surfaces.....	4
2.5 Yellow Cards Rule - A Player Penalty System.....	5
2.6 Team Point Scoring for Fixture Matches.....	5
2.7 Late Starting of Fixture Matches.....	5
2.7.1 Determination of Late Starting of Fixture Matches - Artificial Surfaces.....	5
2.7.2 Penalty For Late Starting of Fixture Matches.....	5
2.7.3 Determination of Late Starting of Fixture Matches – Grass.....	5
2.7.4 Extenuating Circumstances.....	5
2.8 Team Numbers.....	5
2.9 Forfeiture Of Matches.....	6
2.10 Where a Team Withdraws During the Season.....	6
2.11 Supplementary / Back-Up Umpires.....	6
2.12 Ball Attendants.....	6
2.13 Joint Finals Matches.....	6
2.14 Club Days at the SHC.....	6
2.15 Grass Fixture Matches (Classic Hockey League & Juniors).....	6
2.16 Minkey & Modified Competitions.....	6
2.17 Coaching from Back Line.....	6
2.18 Player Substitutions.....	6
2.19 Umpire Examination.....	6
2.20 Fixture Matches During Senior State Titles.....	7
2.21 Head Injuries.....	7
2.22 Banned Play - 'Tomahawk'.....	7
2.23 Veteran's Hockey League (VHL).....	7
3 REGISTRATION SYSTEM.....	8
3.1 Players Eligible for Finals.....	8
3.2 Registrations.....	8
3.2.1 Competitions.....	8
3.2.2 Team Registrations.....	9
3.2.3 Player Registrations.....	9
3.2.4 Player Registration Number.....	9
3.2.5 New Player Registrations.....	9
3.3 Number of Players to be Registered in a Team/Competition.....	9
3.4 Requirement of List of Players in Any Matches.....	9
3.5 Juniors Playing in Senior Matches.....	9
3.6 Playing in a Lower Competition/Division.....	9
3.7 Re-registration of Players.....	9
3.8 President's Trophy and Memorial Cup.....	10
3.8.1 President's Trophy.....	10
3.8.2 Memorial Cup.....	10
3.9 Transfers and Clearances (Also see BHA By-laws "Part D – Competitions").....	10
4 PROMOTION AND RELEGATION.....	10
4.1 Promotion.....	10
4.2 Relegation.....	10
5 CONTROL OF MATCHES - ARTIFICIAL SURFACES.....	11
6 REQUIREMENTS FOR TEAM CARDS OR SHEETS AND RESULT SLIPS.....	11
6.1 Results.....	11
6.2 Team Sheets (or Cards).....	11
6.3 Premiership Points Table.....	11
6.4 Temporary Suspensions.....	11
6.5 Permanent Suspensions (Red Card).....	11
7 BHA BEST & FAIREST MEDAL SCORING SYSTEM.....	12
8 PREMIERSHIP FINALS SERIES, PRESIDENT'S TROPHY & MEMORIAL CUP.....	12
8.1 Playing Surfaces to be Used.....	12
8.2 Determining Premiership Ladder Placings.....	12
8.3 Minor Premiership.....	12
8.4 Finals Playoff Procedure.....	12

8.5 President's Trophy and Memorial Cup.....	14
8.6 Drawn Matches – Memorial Cup, President's Trophy & Premiership Finals.....	14
8.7 Determination of an Outright Winner – Memorial Cup, President's Trophy & Premiership Finals.....	14
8.7.1 Drop-off Rules.....	14
8.7.2 Penalty Stroke Competition.....	14
8.8 Special Events.....	14
9 COMMUNICATIONS.....	14
9.1 Hockey Information Service & Wet Weather Procedures.....	14
9.1.1 Wet Weather Information.....	14
9.1.1 Postponement of Matches.....	15
9.2 All Enquiries & Booking of the Artificial Surfaces.....	15
9.3 Communication with BHA Office.....	15
9.4 Courtesy In Communications.....	15
9.5 Player Insurance Claims.....	15
10 ARTIFICIAL SURFACE RULES.....	15
11 REGISTERED BHA HOCKEY CLUB FIELDS & VENUES.....	16
11.1 Numbering and Locations.....	16
12 USING THE BHA TEAM & MATCH RECORD SHEETS.....	17
12.1 The Match details.....	17
12.2 The Players' details.....	17
12.3 The Team Officials' details.....	18
12.4 Goals and Offences.....	18
12.5 Goal Summary.....	18
12.6 Set Play Summary.....	19
12.7 Misconduct & Offence Summary.....	19
12.8 Checking & Signing.....	19
12.9 Completed Sheets.....	20
13 BHA COMPETITION FORMS.....	20
13.1 Application for the Registration of Club Teams.....	21
13.2 Team Registration Form.....	22
13.3 Player Registration Re/De-registration Form.....	23
13.4 Member Registration Form (Typical).....	24
13.5 Incident Report.....	25
13.6 Team & Match Record.....	26

1 BHA FIXTURE STRUCTURE FOR 2004

The 2004 Brisbane Hockey Association Inc competition fixtures are as follows:

COMPETITION NAME	DIVISIONS	NUMBER OF TEAMS
Brisbane Hockey League (BHL)	1 to 5	Generally 8 with a minimum of 6 per division
Classic Hockey League (CHL)	1 & 2	Generally 8 with a minimum of 6 per division
Veterans Hockey League (VHL)	1 (or more)	As recommended by the B.H.A. Veterans' Committee
Juniors	Under 17	As recommended by the
Juniors	Under 7 to Under 15	B.J.H.A. Committee

There will be a minimum number of eighteen (18) matches for all divisions (seniors and juniors).

There will be only full rounds in all divisions (seniors and juniors) unless decided by the Board.

The General Committee reserves the right to grade all teams in any division or competition.

2 LOCAL RULES

The Board has discretionary powers over these Competition Rules and Requirements with respect to interpretation and application.

2.1 Local Competition Rules

These local rules shall prevail over any other rules. The order for applying rules is as follows:-

1. Local Rules;
2. International Rules (as per rule book)

2.2 Penalty Corners

At half-time or full-time the match shall be prolonged to permit completion of a penalty corner. For this purpose the penalty corner shall be considered completed when:

1. A goal is scored, or
2. an attacker breaches any Rule, or
3. a defender commits a breach of the Rules during the taking of such a penalty corner and another penalty corner or a penalty stroke is awarded, the match shall be prolonged again to permit completion of the penalty corner or penalty stroke, or
4. the ball travels more than 5 metres outside of the circle, or
5. the ball is played out of the circle over the back-line by an attacker or unintentionally by a defender, or
6. the ball goes out of the circle, over the circle-line, again (that is for a second time) after the initial injection from the back line.

2.3 Template & Starting Times for Matches on Artificial Surfaces

The template has changed considerably for this (2004) season following negotiation and agreement between BHA, BWA and Hockey Queensland (SHC). In general terms: BHL 1 and 2 will be played on Saturday afternoons only; BHL 3, 4 and 5 will be played on Sundays only, with 'overflow' matches played on Saturday as required; VHL 1 and 2 will be played only on Tuesday nights only at the SHC.

BHL (Senior) matches will consist of 35 minute halves with a 5 minute half-time break, while both VHL (Veterans) and Junior matches will consist of 30 minute halves with a 5 minute half-time break.

Starting times for matches on Saturdays and Sundays are as follows: 1:45pm; 3:15pm; 4:45pm; 6:15pm & 7:45pm. Overflow matches on the weekend may also be scheduled to 12:15pm and 9:15pm as required. Starting times for VHL matches on Tuesday nights shall be as follows: 7:00pm; 8:10pm & 9:20pm.

Variations of these times may be considered by the Board from time to time.

2.4 Time Keeping for Matches on Artificial Surfaces

Central Timing will be enforced during all matches played at SHC and at the Burringbar Pk Facility.

Where matches are timed by technical officials or by means other than the umpires, the matches will be started and re-started by the umpires but the match will end on the siren at the end of the required period of time except in the case of extension of time to allow for the completion of a penalty corner or penalty stroke in which case the match will end on the umpires' whistle.

Time off during fixture matches will not be permitted. Time off will be permitted during Memorial Cup, President's Trophy and Finals' series matches.

However, match time may be lost for various reasons such as serious injury or when the playing surface has become unplayable, e.g. excessive water (rain) on the surface, etc.

Where players incur a serious injury and cannot be removed from the field for a period greater than 15 minutes then the match shall be abandoned unless otherwise agreed by the team captains. Umpires are required to ensure that all injured players leave the field as quickly as possible.

Where the venue manager rules that the playing surface is unplayable and more than 15 minutes of playing time is lost then the match shall be abandoned.

Where the team captains and umpires agree that a surface is unplayable for a period in excess of 15 minutes then the match shall be abandoned.

Abandoned matches shall be rescheduled by the Board.

2.5 Yellow Cards Rule - A Player Penalty System

In addition to all Senior Competitions this rule has been extended to incorporate the U17 Competition with points accumulated in any of these competitions being cumulative and reciprocal.

A points system is in place for yellow cards whereby 'major' yellow cards equate to ten (10) points and 'minor' yellow cards equate to five (5) points. It is therefore essential that when issuing a yellow card to a player that an umpire must indicate whether they are issuing a 'major' (10 minutes/points) or a 'minor' (5 minutes/points) yellow card. All yellow cards issued during a match must be accurately recorded on the team sheets with either a '10' or a '5' recorded in the Yellow Card column beside the relevant player. If the umpire does not signal or there is an indication of a yellow card on the team sheet without '5' or '10' then it is assumed that it is a '5' point yellow card.

During a match, the second minor yellow card (5 min) received by a player may (at the discretion of the relevant umpire/s) convert to a "progressive red" card while a second yellow card when at least one of those is a major yellow card (10 min) is likely (at the discretion of the relevant umpire/s) to convert to a "progressive red" card.

When a player has accumulated twenty (20) points, or more, within a six (6) match period (matches in which a player has actually participated), a player shall be automatically suspended for eight (8) days, effective at the end of the fixture in which the most recent card was received and the suspension will remain at the BHA Board's discretion. The Club Secretary will immediately inform the BHA General Secretary. Once a suspension has been served, the player may resume playing with a 'clean slate'.

Failure to inform the BHA General Secretary may mean that further penalties will be imposed by the BHA Board with the proviso that the BHA General Secretary continuously tracks yellow card offences.

2.6 Team Point Scoring for Fixture Matches

During the fixture competitions for all divisions, three (3) points will be awarded for a win, one (1) point will be awarded for a draw, three (3) points will be awarded for a bye and three (3) points and three (3) goals to nil will be awarded for a forfeit.

2.7 Late Starting of Fixture Matches

2.7.1 Determination of Late Starting of Fixture Matches - Artificial Surfaces

All artificial surface matches must start on time in accordance with the times set down in the fixtures of the Association. Any team or teams not prepared to start on time shall be fined fifty dollars (\$50) by the Board. The decision of the Umpires or Technical Bench Officer in charge of matches shall be final as to whether any team is late. If any team is, in the opinion of the Board persistently late, the Board may increase the amount of the fine.

2.7.2 Penalty For Late Starting of Fixture Matches

Unless good and sufficient reason for the delay can be shown to the Board, then the team prepared to play will be awarded the match as a forfeit.

2.7.3 Determination of Late Starting of Fixture Matches – Grass

If after a period of fifteen (15) minutes a team does not take the field a forfeiture will be awarded to the team ready to play.

2.7.4 Extenuating Circumstances

The Board has discretionary powers to consider extenuating circumstances in the case of forfeits.

2.8 Team Numbers

Teams may be completed to their full strength of eleven (11) players at any time during the match provided that the names of the players agree with the list handed to the umpire prior to the commencement of the match and provided that no team shall take a field

with less than eight (8) players. Up to sixteen (16) players may be used in any fixture match, but only a maximum of eleven (11) players per team is permitted in play, therefore, a maximum of five (5) substitutes is permitted.

2.9 Forfeiture Of Matches

Any Club receiving a forfeiture shall be credited with three points and shall be treated as having scored three (3) goals to nil. Any team giving a forfeit will be treated as having lost the match three (3) goals to nil. In the event of two opposing teams giving a forfeit, the points score by each team shall be nil and the goals scored shall be nil.

For the purpose of these rules a forfeit shall be deemed to have arisen when one team, on the day of play, either fails to appear at the time set down for play, within such time specified in these rules, and without notification that such team intends to forfeit, or appears at the playing ground with less than eight (8) players. In such case the opposed team, before being credited, is to take the field and to comply in all respects with the requirements of these rules as fully as if the opposing team had appeared, PROVIDED HOWEVER that such team shall not be required, when having taken the field, to take any further part in this match.

2.10 Where a Team Withdraws During the Season

In the event of a Club withdrawing a team during the season, then all matches scheduled for that team shall be deemed null and void.

In the event that a complete round/s has/have been played then a new draw shall be made.

Where a team is withdrawn after the start of fixtures, the Club withdrawing such team will be liable for any costs in connection with the registration of such team with the BHA and Hockey Queensland.

2.11 Supplementary / Back-Up Umpires

Where numbers permit, the Brisbane Hockey Umpires Association will appoint official umpires to matches. It is the Clubs' responsibility to supply umpires for matches in the manner prescribed by the Board, even though an official umpire may be allocated to a specific match. Players who are designated by their Club to umpire a particular match, as per the fixture list, must be in attendance at the start of the match in case the official umpire cannot umpire that match. Any Club whose member is unable to carry out the assigned umpiring duties shall be guilty of an infringement of the rules and the relevant Club shall receive an automatic penalty of fifty dollars (\$50) per offence. Where one Club has supplied an umpire for another Club, the Club which completed the umpiring duty will be awarded the fifty dollars (\$50) fine upon application.

2.12 Ball Attendants

During normal fixture matches the use of Ball Attendants will only be permitted if both teams agree.

2.13 Joint Finals Matches

Generally, the Joint Finals will include Division Two Women, Division One Women, Division Two Men and Division One Men. Division Three and Four matches will also be played, generally on Field 2. The match times and field allocations will be determined by a Joint Committee made up of representatives from the BHA, BWA and the SHC.

2.14 Club Days at the SHC

Any Club wishing to have a Club Day shall negotiate with the BHA Director of Competitions prior to the creation of the season's fixtures. Grass competition Club Days will be considered where possible.

2.15 Grass Fixture Matches (Classic Hockey League & Juniors)

For the 2004 Season a Central Venue approved by the Board will be utilised for the Senior and Junior Competitions.

2.16 Minkey & Modified Competitions

The Under Seven (Minkey) and Under Nine (Modified) competitions shall be localised wherever possible. The competitions may involve a single club or several clubs. Clubs are to ensure that such competitions adhere to the rules of hockey including the rules and requirements of BHA Inc and will at all times be considered as being under the control of BHA Inc. (i.e. Playing venues included in fixture allocations)

2.17 Coaching from Back Line

Coaching from the back line is prohibited for all Senior and Junior Competitions. Penalties will be invoked for breaches of this rule.

2.18 Player Substitutions

All player substitutions (BHL, CHL, Vets and Juniors) must be effected from the half-way line. Substitutions during grass matches may be made from either side of the field provided that all players enter and leave from the same side. If a Technical Bench is in operation substitutions will enter and leave from the same side of the field as the Technical Bench.

2.19 Umpire Examination

All players must sit and pass an umpiring examination compiled by BHA and monitored by the clubs.

2.20 Fixture Matches During Senior State Titles

Matches as determined by the Board may be scheduled on the weekend of the State Senior Titles and/or Premier League.

2.21 Head Injuries

Where a player has been knocked unconscious ('knocked out') or on the advice of the First Aid Officer that a player not participate any further in the match the injured player:

- (a) must take no further part in the match in which he was injured
- (b) must not take part in any other hockey match on that day, and,
- (c) must produce a medical certificate from a doctor which clears the player to resume playing

Where a player refuses to leave the field for any of the aforementioned instances the umpires or the relevant officials must order the said player from the field and not resume the match until this has occurred. Where a player continues to refuse to leave the field or continues to disrupt any match the said player will be cited for misconduct.

With regard to (c) above (mandatory medical certificate) the player's Club Secretary must forward such certificate to the BHA Office before the said player resumes playing whether that be at any level of participation.

2.22 Banned Play - 'Tomahawk'

The 'tomahawk' method of striking the ball is banned in all BHA divisions/competitions with the exception of the BHL1 and BHL2 divisions where this 'skill' is expected of players at representative level. The tomahawk is defined as "a backhand hit with a wind-up, using the edge of the stick."

2.23 Veteran's Hockey League (VHL)

The following rules apply exclusively to the Veteran's Hockey League. They have been developed over time in order to account for some of the difficulties involved in the management of a competition for this age group and the fact that it is also exclusively a mid-week competition. These rules are the product of recommendations made by the Brisbane Veteran's Committee to the BHA Board and their subsequent ratification by the Board.

- 2.23.1 All players participating in the VHL Competition must be aged 40 or more by the 31st December of the year in which they are participating.
- 2.23.2 To allow three (3) matches per night to be scheduled during the 2004 Season, matches will consist of 30 minute halves with a 5 minute half-time break and 5 minutes between matches. Starting times shall be as follows: 7:00pm; 8:10pm & 9:20pm.
- 2.23.3 An umpire's duty may be shared by two players in recognition of the limited time available between matches for players to dress and warm up. Umpires must ensure that all matches commence on time.
- 2.23.4 Should a team not be able to field a full compliment of eleven (11) players for a match then it is permissible to "borrow" one or more players from another competing team in order for the match to go ahead. In such circumstances a team is only permitted to "borrow" sufficient players in order to obtain a maximum of eleven (11) players participating in the match.
- 2.23.5 In circumstances where both teams are "borrowing" players for a match neither team may gain a numerical advantage over the opposing team using this process.
- 2.23.6 Substitution of players injured during a match by the process of "borrowing" a player will only be permitted with the consent of the opposing team's captain.
- 2.23.7 Goalkeepers may interchange between teams.
- 2.23.8 Washed-out matches will be treated as a scoreless draw and will not be rescheduled. This is necessary due to the already tight scheduling of the competition and the lack of suitable mid-week timeslots available on the artificial surfaces.
- 2.23.9 For a player to be eligible for the finals' series a player must have played 30% of fixture matches available to that player's team during the season. Should a player not meet this criterion then special approval must be sought in writing from the BHA Board via the Brisbane Veteran's Committee. Matters to be considered might include: player injury, work commitments or transfers, travel, etc. (See also 3.1.4)

3 REGISTRATION SYSTEM

Competing Clubs shall nominate **teams** for registration with the BHA using the "**Application for the Registration of Club Teams**" Form. Refer to **Form 13.1** (attached). Competing Clubs shall nominate their **players** for registration with the BHA using the "**Team Registration Form**", prior to the commencement of the start of the first fixture. Players' names must appear in alphabetical order with the surnames first. Refer to **Form 13.2** (attached).

Competing Clubs shall register eleven (11) players in each senior division for which they have nominated prior to the beginning of the first fixture (per division) with players only then being able to play in divisions upwards.

Where a player is registered in a particular division that same player can play an unlimited number of matches in the next immediate higher division for his Club. If the same player were to play four (4) matches above his next immediate division then that player would be immediately registered in the highest division he has played.

Should a player miss four (4) matches in succession in their registered division then that player will be automatically re-registered in the division below.

No A.H.L. player can play below BHL 1 (Division One). If a player has been out of competition with a serious injury a written request to the BHA Board to play in a lower grade may be considered.

Players competing in the BHA Veterans Competition who are genuine Veterans, i.e. over 40 years of age, can play in any BHA competition for their Club without penalty.

At all times the Brisbane Hockey Association Board shall administer de-registrations and/or re-registrations including players coming back after a lengthy period of injury. Club Secretaries are to use the prescribed form "**Player Registration Re/De-registration Form**" for this purpose. Refer to **Form 13.3** (attached).

Infringements of the registration system will result in a fifty dollar (\$50) fine increasing by fifty dollars (\$50) for each subsequent infringement.

3.1 Players Eligible for Finals

- 3.1.1 A player registered in a division/competition must have played 50% of the fixture matches in that division/competition for that season (whereby one (1) week equals one (1) fixture match).
- 3.1.2 A player must have played at least 50% of the fixture matches **in the division in which he is registered**.
- 3.1.3 Any player who has played the required number of fixture matches to qualify for semi-finals and finals in a division may play in any higher division.
- 3.1.4 The Veterans competition is not considered a lower division but a separate competition. For veteran players (over 40) to be eligible for semi-finals and finals in any other division other than their own the said player must have played a minimum of half (50%) of possible matches in that division. (See also 2.23.9)
- 3.1.5 The Brisbane Hockey Association Board has the authority to consider special cases in relation to the eligibility of players to play in semi-finals and finals of any division.

3.2 Registrations

A player cannot be registered in any division/competition with more than one Club. The Board may consider a relaxation of this rule, but only under exceptional circumstances, for example, where a player's Club does not have:

- ◆ A Veterans team or
- ◆ An Under 17 team

3.2.1 Competitions

The BHA competitions will be as follows:

- ◆ Divisions 1 - 7 (BHL 1 - 5 play on artificial surfaces while CHL 1 & 2 play on grass.)
- ◆ Veterans (Note that this is a separate competition played on artificial surfaces.)

The **BJHA** divisions/competitions will be:

- | | |
|------------|----------------------|
| ◆ Under 17 | ◆ Under 11 |
| ◆ Under 15 | ◆ Under 9 (Modified) |
| ◆ Under 13 | ◆ Under 7 (Minkey) |

BHA will determine:

- ◆ The number of teams per division, and
- ◆ The extent and make-up of all divisions.

The **minimum** number of **fixture matches** to be scheduled for any division per season shall be **18 matches**. This rule applies to both BJHA and BHA competitions.

3.2.2 Team Registrations

Competing Clubs shall nominate **teams** by division or by competition in the case of the Veterans (as listed in 3.2.1 above) for registration with the BHA using the "**Application for the Registration of Club Teams**" Form. Refer to **Form 13.1** (attached). Until these forms are received from all clubs the creation of the fixture draw cannot begin. Therefore a suitable closing date for the submission of this form will be decided by the BHA Board.

3.2.3 Player Registrations

Each individual player must complete, sign and lodge **with their club** the prescribed "**Member Registration Form**" or similar. Refer to **Form 13.4** (attached). Registration details shall include the players full name, address, telephone number and date of birth, together with a clearance where relevant (See Section 3.9 Transfers and Clearances) and dual registration details declared, i.e. primary and secondary registrations as relevant. Club Secretaries are to transfer each member's details to the prescribed electronic format (currently FormMax Filler) for transmission to the BHA Office.

In addition, competing Clubs shall nominate their **players** for registration by competition or division (as listed above) with the BHA using the "**Team Registration Form**" prior to the commencement of the start of the first fixture. This form is used to declare to BHA the registered division (and team) of each player. Players' names must appear in alphabetical order with the surnames first. Refer to **Form 13.2** (attached).

3.2.4 Player Registration Number

Each registered player is to be issued with a player registration number by their club. The BHA General Committee will stipulate the prescribed format of such numbers.

3.2.5 New Player Registrations

No player may participate in any match unless such player is officially registered with the Association. Refer to 3.2.3 above. However, following the playing of the first fixture of a season, Club Secretaries are to use the prescribed form "**Player Registration Re/De-registration Form**" for this purpose (refer to **Form 13.3**, attached) in lieu of using the "**Team Registration Form**".

3.3 Number of Players to be Registered in a Team/Competition

A Club/Association with a single team in the BHA competition structure must have sixteen (16) registered players. A minimum of eleven (11) players per team should be otherwise registered in both Junior and Senior competitions.

Any Club found guilty of taking the field with more than eleven (11) players in any team in any match will receive an automatic penalty of the loss of points for that team for that match and a fine of fifty dollars (\$50) in respect of every player so infringing.

3.4 Requirement of List of Players in Any Matches

Before the commencement of any match, the Captain/Manager of each team will hand to the umpire or technical bench a list of the players in the team, as prescribed by the BHA Board. No match can proceed until such team lists are received by the umpires or technical bench. Where a central control (technical bench) is in operation the prescribed sheet will be handed to the person in charge of the central control. At artificial surface venues only the people named on the prescribed sheet (maximum of nineteen) will be permitted in the dugout at any time. (See also Sections "6.2 Team Cards or Sheets" & "12. Using the BHA Team & Match Record Sheets")

Should any team fail to submit such a list to the umpire or officer in charge of the central control, the same shall be recorded and such Club shall be liable to a fine of no less than twenty-five dollars (\$25) for the first offence, increasing to fifty dollars (\$50) for the next offence, and if any further offences occur, loss of points may occur as per discretion of the Board.

3.5 Juniors Playing in Senior Matches

There is no restriction on the number of matches a registered junior may play in senior matches in any Division but the letters "(JNR)" must appear beside the players name on the Team Card/Sheet.

Junior Players between 13 years to 17 years are not permitted to play in senior divisions unless Parental permission is given in writing to the Club of which he is a member. A copy must also be lodged with the BHA.

3.6 Playing in a Lower Competition/Division

No player may play in a Competition/Division lower than that in which that player is registered.

3.7 Re-registration of Players

If the necessary re-registration form/s (refer to **Form 13.3**, attached) for player/s are not submitted by the required time the team may lose points for the match in which the change took place. The deadline (minimum) for any re-registration for any match,

including mid-week matches, is twenty-four (24) hours prior to the playing of the fixture.

No player shall be permitted to be re-registered during the final round of Premiership matches without the consent of the Board.

No player who, or belonging to a team which, has been suspended or disqualified or which has been disbanded, shall be permitted to play in another team without first obtaining the sanction of The Board and paying the Association a proportion on a per capita basis of fees due by the Club of which he was a member as determined by The Board.

3.8 President's Trophy and Memorial Cup

Where possible the preferred option is to run these events in conjunction with BWA and/or BJHA.

3.8.1 President's Trophy

To qualify for the President's Trophy a player must have played a minimum of 50% of the matches relevant to the President's Trophy round in that particular division. However, upon application, the Board may decide on a player's status for such events.

3.8.2 Memorial Cup

To qualify for the Memorial Cup a player must have played the equivalent number of matches for a full round in that particular division. However, upon application, the Board may decide on a player's status for such events.

3.9 Transfers and Clearances (Also see BHA By-laws "Part D – Competitions")

Clearances from the previous Club are required whenever a player registers with a new Club. It is the responsibility of the individual Clubs to exchange Clearances. However, the Board may require the Club to submit to the Association a clearance from any previous Hockey Club of which the nominee has been a member, stating that the nominee has no outstanding financial obligations to that club. If such a clearance is not forthcoming, the Board may prohibit that player from competing in BHA competition/s.

If any Hockey Club lodges with the Association a claim setting forth any outstanding financial obligation that a member of the Association has to that Club, the Board may prohibit that member from competing in any competition organised by the Association for such time as it sees fit; provided that such prohibition shall be lifted upon receipt of a clearance from the Club by which the claim has been lodged.

Notice of prohibition shall be given in writing by the Secretary/General Secretary of the Association to the Secretary of the competing Club that nominated the member. The prohibition may not be applied retrospectively prior to the start of the current season. Clearances should be sought to avoid the possible loss of competition points.

4 PROMOTION AND RELEGATION

4.1 Promotion

- (a) Eligibility for promotion is automatic for any Club team into the next highest division where that team has won the minor premiership and won the premiership, and, where that Club has no team in the next highest division. Such promotion will not apply if the Board or General Committee concludes it to be detrimental to the competition.
- (b) Any Club team winning either the minor premiership or premiership will upon request, be automatically eligible to be promoted to the next highest division, but only if that team's Club does not already have a team in the next highest division. Such promotion will not apply if the Board or General Committee concludes it to be detrimental to the competition.
- (c) Notwithstanding paragraphs (a) and (b) above any Club team can be promoted or relegated into any division but only at the discretion of the General Committee.

4.2 Relegation

- (a) Where a team has been promoted into a higher division, the Board or General Committee may decide to relegate the team that finished last in that higher division.
- (b) Upon recommendation from the Board, the General Committee may decide to relegate a team for the best interests of the competition.

5 CONTROL OF MATCHES - ARTIFICIAL SURFACES

The Board will endeavour to appoint Technical Bench Officers wherever possible. The relevant duties are as follows:-

- (1) Ensure that all yellow cards are registered on the prescribed team card/sheet.
- (2) Ensure that all match cards/sheets are returned to the General Secretary of the BHA.
- (3) Operate the score board, where relevant.
- (4) Ensure that all artificial surface rules are adhered to by players and officials.
- (5) Ensure that player behaviour is appropriate for the circumstances.
- (6) Report to the Board in writing, any instances of misconduct, not reported by an umpire, using the prescribed "**Incident Report**" form. (Refer to **Form 13.5**)

Each team playing on an artificial surface shall provide one person to assist either the Technical Bench officer/s or the BHA official in charge of the match.

6 REQUIREMENTS FOR TEAM CARDS OR SHEETS AND RESULT SLIPS

6.1 Results

At all grass venues it is the responsibility of the canteen convenor to communicate the results of fixtures played at that venue to the person appointed by the Board *no later than 6.00 pm* on the day the fixtures are played.

At all centrally controlled venues it is the responsibility of the person in charge of the Technical Bench to communicate the results of fixtures played at that venue to the person appointed by the Board on the day the fixtures are played. The results of all matches completed at centrally controlled venues prior to 6.10 pm shall be communicated to the person appointed by the Board *no later than 6.30 pm*. The results from any remaining matches played at that venue after 6.10 pm shall be communicated to the person appointed by the Board at a later time on the day the fixtures are played.

6.2 Team Sheets (or Cards)

Team sheets (or cards) must be presented to the Umpire/Technical Bench, prior to a fixture match. Refer to Section 12 "*Using the BHA Team & Match Record Sheets*" & **Form 13.6**. Team sheets must be correctly filled in with surname first, followed by full given name. Junior players playing in all senior matches must have the following letters in brackets entered beside their name: "(JNR)". When playing in either the BHL or the CHL divisions, players registered in the VHL must have the following letters in brackets entered beside their name: "(VHL)". Insert "(C)" beside the name of the Captain of the team. For Divisions BHL 1 - 4 each player's individual shirt number must appear on the team card.

The players' registration numbers must appear in the designated space on the team sheet (or card) when such a system is in place (refer 3.2.4).

Team sheets are in duplicate with the top (original) leaf to be submitted to the BHA Office and the duplicate retained in the book for the Club's records.

CHL team sheets (originals) from Saturday fixture matches must be in the hands of the BHA General Secretary by 5pm the next Monday. CHL team sheets (originals) from Sunday fixture matches must be in the hands of the BHA General Secretary by 5pm the following Tuesday. It remains the responsibility of the host Club to ensure that these deadlines are met. At the discretion of the Board a fine of one hundred dollars (\$100) for the first offence with subsequent increases of fifty dollars (\$50) per offence will be incurred by the host Club if the above practice is not followed.

For the BHL and VHL competitions it is the responsibility of the Technical Bench personnel to ensure that the team sheets (originals) are returned to the BHA General Secretary within twenty-four (24) hours of the match being played. At the SHC a set of clearly marked pigeon holes is provided immediately inside of the SHC Reception (to the right) for this purpose.

Captains should check that the scores and other relevant information have been correctly recorded before signing at the completion of the match. Team cards and sheets are considered by the Association as official correspondence. All team cards and sheets must be legible in all respects. Failure to comply with this may result in a fine of one hundred dollars (\$100).

6.3 Premiership Points Table

The Board will publish on a regular basis Premiership Points Tables for each competition/division.

6.4 Temporary Suspensions

Temporary suspensions (yellow cards) must be accurately recorded on the team sheets in all divisions. The length of each such suspension must also be accurately recorded, i.e. 5 or 10 minutes.

6.5 Permanent Suspensions (Red Card)

- 6.5.1 For grass fixture matches the relevant umpire/s must report such suspensions before 6:00 pm that evening to the Association's answering service or by direct communication with the BHA General Secretary.

6.5.2 For artificial surface fixture matches the person in charge of the Technical Bench must report such suspensions that evening to the Association's answering service or by direct communication with the BHA General Secretary. In the absence of a Technical Bench the relevant umpire/s are responsible for reporting such suspensions to the Association's answering service as above.

The telephone number for the Association's answering service is **3899 4399**. Failure to comply with either of the above may result in the levying of penalties by the Board.

N.B. In either case the player and umpire involved will be expected to attend a judiciary hearing on the next Monday evening (unless a Public Holiday) immediately following the incident, at the BHA Office (SHC) at 6:30 pm or any other time or place as determined by the Board unless otherwise instructed by the BHA General Secretary.

7 BHA BEST & FAIREST MEDAL SCORING SYSTEM

The award for the "best and fairest" player in the BHL 1 competition is currently known as the "BHA Best and Fairest Medal". Points are allocated for each fixture match on a 3, 2 and 1 basis. The player with the most points at the end of the season is the winner. An award is also made to the player receiving the most points for each club.

The Board will decide the method/system to be used for awarding the best and fairest points.

A player receiving a red card and found guilty of an offence resulting in a fine or suspension shall be disqualified from winning the medal. Players who have *not* registered "Brisbane" as their Primary Association will not be eligible for "best and fairest" points, unless permitted by the Board.

No draws are permitted and players receiving equal points at the end shall be separated by count back. The player receiving the most three point awards shall be declared the winner. If the count is still equal then the player receiving the most two point awards shall be declared the winner. If the count is still equal then the player receiving the lesser number of yellow cards shall be declared the winner. Final determination of the winner if necessary shall be made by the senior selection panel and by a cut of cards or any other method approved by the Board for individual team winners.

8 PREMIERSHIP FINALS SERIES, PRESIDENT'S TROPHY & MEMORIAL CUP

8.1 Playing Surfaces to be Used

All Senior and Veterans Semi-finals, Preliminary Finals, Grand Finals, President's Trophy and Memorial Cup Finals matches shall be played on the same surfaces used for fixture matches unless otherwise decreed by the Board. However, where division one junior teams play the majority of their scheduled fixture matches on artificial surface they shall play their semi-final and finals series on the artificial surface.

8.2 Determining Premiership Ladder Placings

After completion of all competition (fixture) matches, team placings on the premiership ladder shall be determined for each division. Premiership points awarded throughout the season are totalled and the premiership ladder is arranged in descending order, i.e. the team with the most premiership points appears at the top of the premiership ladder. In the event of equal points, the team with the greater goal difference shall be placed higher on the premiership ladder.

8.3 Minor Premiership

On completion of the premiership rounds the team leading the premiership ladder shall be declared Minor Premiers.

8.4 Finals Playoff Procedure

For a competition/division comprising of nine (9) teams or less the finals series shall be contested by the teams finishing 1st, 2nd, 3rd & 4th on the premiership ladder. For a competition/division comprising ten (10) teams or more the finals series shall be contested by the teams finishing 1st, 2nd, 3rd, 4th & 5th on the premiership ladder. Other play-off procedures may be considered by the Board from time to time. The play-off procedures are detailed in Figures 1 & 2.

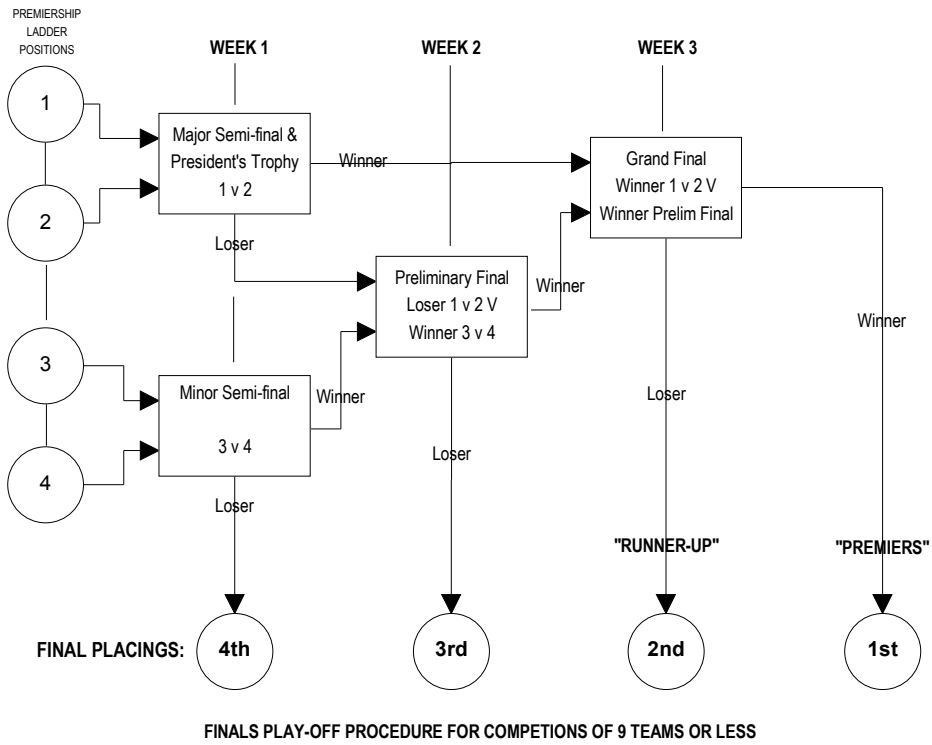

Figure 1

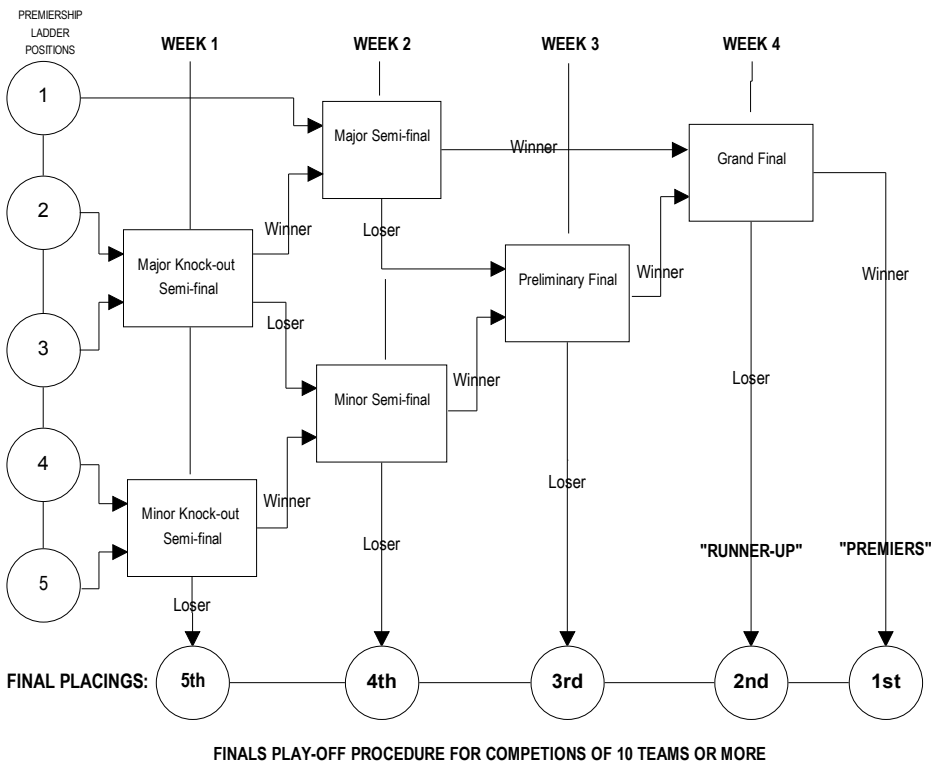

Figure 2

8.5 President's Trophy and Memorial Cup

President's Trophy and Memorial Cup shall be conducted under the conditions as determined by the Board. In general, they shall be contested by two teams leading on points in their respective divisions at the conclusion of the first round of Premiership fixtures in the case of the President's Trophy and at the conclusion of the second round of the Premiership fixtures in the case of the Memorial Cup or a special competition as determined by The Board.

8.6 Drawn Matches – Memorial Cup, President's Trophy & Premiership Finals

In such matches where the scores are equal at the conclusion of normal playing time, the winner shall be determined on the playing field as per the following "Determination of an Outright Winner" section.

8.7 Determination of an Outright Winner – Memorial Cup, President's Trophy & Premiership Finals

When the scores are equal at the conclusion of normal playing time in Memorial Cup, President's Trophy, Semi-finals, Preliminary Finals and Grand Finals an outright winner shall be determined by extending the duration of the match in accordance with the rules for "Drop-off" as follows:

8.7.1 Drop-off Rules

- (a) At the conclusion of normal time there will be a five (5) minute rest during which time the captains will toss a coin to decide ends.
- (b) For the first five (5) minute period of "golden goal extra time", each Team shall nominate nine (9) players, including a goalkeeper, to take the field.
- (c) After the first five (5) minute period, teams shall remove two (2) players and immediately change ends for re-commencement.
- (d) For the second five (5) minute period of "golden goal extra time", only seven players from each Team, including the goalkeeper, shall take the field.
- (e) After the second five (5) minute period, teams shall remove two (2) players and immediately change ends for re-commencement.
- (f) For the third period of "golden goal extra time", fifteen (15) minutes will be played and only five (5) players from each Team, including the goalkeeper, shall take the field.
- (g) Normal interchange rules will apply during extra time.
- (h) "Golden goal" means the match will conclude once the first goal has been scored.
- (i) If the scores are still equal at the end of "Drop-off" then a Penalty Stroke Competition will follow for the determination of an outright winner.

8.7.2 Penalty Stroke Competition

- (a) Five (5) players from each of the two (2) Teams, chosen by their respective Captains from the players listed on the Team Card/Sheet, but excluding any player who is under suspension by either the umpires or the Technical Bench, shall take part.
- (b) The Captains shall choose five (5) players of their own Team and shall determine the order in which their own players shall take each penalty stroke against one and the same goalkeeper of the other Team (unless incapacitated).
- (c) The umpires shall choose the goal to be used and the Captains shall toss to decide which Team shall appoint one (1) of its five (5) players to take the first stroke.
- (d) If no decision is reached after the first series of strokes, a "golden goal" procedure will then operate, consisting of a further series of penalty strokes by the same group of players, in any sequence. The Team from which a player has taken the first penalty stroke of a series shall not take the first penalty stroke of the next series.
- (e) The first Team to score more goals than their opponents from an equal number of strokes shall be declared the winner of the match.

8.8 Special Events

The Board shall determine all of the requirements for special events.

9 COMMUNICATIONS

9.1 Hockey Information Service & Wet Weather Procedures

The Hockey Information Service telephone number is **1900 962 018**. The purpose of this recorded service is to provide important information from time to time regarding wet weather, special events etc. While BHA is the subscriber to this service, its use has been extended to incorporate other Brisbane Hockey entities, including the SHC, BWHA and Shaw Sportz. A voice menu system guides callers to the appropriate recorded message.

9.1.1 Wet Weather Information

Should there be any doubt in relation to field conditions due to inclement weather the following procedure will occur:

The Grounds Committee (and/or the Board) inspects the necessary fields and makes the appropriate decision. In the case of commercially operated facilities such decisions are made by a representative of the facility.

This information is then passed on to the person authorised to operate the BHA Information Service. This person then updates the BHA Information Service with this information.

Players, parents and officials can then call the Hockey Information Service on **1900 962 018** at their convenience to receive up to date information on field conditions. During wet weather all players and officials are encouraged to ring the Hockey Information Service prior to their departure for matches to ascertain if venues are playable.

9.1.1 Postponement of Matches

In the event of the grounds being determined as unfit for play the matches will be postponed to a future date to be arranged by the Board. If a suitable date is not available the Board will decide what actions to take.

When a BHA Official is not available the Captains shall endeavour to decide a ground's suitability for play and in the event of disagreement the umpires shall decide.

9.2 All Enquiries & Booking of the Artificial Surfaces

All Clubs and their members are to book artificial surface time for training purposes directly with the respective venue operators only. Clubs will be billed directly by the venue operator. The respective contact numbers for the venues are:

State Hockey Centre (SHC)	3217 9922 or 0418 191 451
Burringbar Park Facility (ShawSportz)	3260 5020 or 0411 457 732

9.3 Communication with BHA Office

The telephone number of the BHA Office is **3899 4399**. The telephones at the Brisbane Hockey Association office are generally manned between 9.00am and 5.00pm week days. However, members are asked to limit calls to the office, to the hours between 1.00pm and 5.00pm. This will allow the person/s in the office to complete the daily, routine tasks with minimal interruptions. Requests for information such as fixture/training times should be addressed to the individual's Club Secretary and not to the BHA Office. Should your call not be answered when telephoning the BHA Office please leave a meaningful message on the answering machine. Include your name, contact number and the nature of your enquiry. Your call will be attended to as soon as possible. Alternative methods of communicating with the BHA Office are:

- ◆ by facsimile (fax): **3399 9825**
- ◆ mail: **The Secretary, Brisbane Hockey Association Inc, PO Box 503, MORNINGSIDE Q 4170**
- ◆ email: **secretary@bha.org.au**

Further information such as fixtures, training times, venue locations, Club contacts, etc can also be found on the Internet at: **www.bha.org.au** This information is maintained by the BHA General Secretary.

9.4 Courtesy In Communications

Most people who are involved with Hockey, do so for the love of the sport. Most are volunteers. While there will be disagreements between people from time to time and the occasional mistake made, generally everyone is well intentioned. Most people can accept constructive criticism, however abusive verbal attacks are not acceptable, either on or off the field. *Think before you let fly!*

Most players and administrators alike are employed in full-time or part-time employment. Many employers do not take kindly to continual interruptions of an employee. Limit calls to members' work places as much as possible. Where a person has indicated that they do not wish to be contacted at work, by telephone, fax and/or email, then please comply.

9.5 Player Insurance Claims

Should it be necessary for you to lodge a claim for injury, please contact the insurer, IEA Insurance Brokers, by telephoning **1800 776 781 to request the appropriate (hockey) form**. Alternatively the (hockey) claim form may be downloaded from the **IEA Website: www.ieasport.com.au** - *Do not ring the B.H.A. Office!* Player Insurance is arranged by Hockey Queensland, telephone: 3399 6577.

10 ARTIFICIAL SURFACE RULES

The rules governing the use of the artificial surfaces for matches, training or as supporters is contained in the respective User Manuals. Copies of the **State Hockey Centre User Manual 2004** have been mailed to each of the BHA registered Clubs by the State Hockey Centre Management. Further copies are available at all times from the State Hockey Centre office and the entrance gates when in operation.

11 REGISTERED BHA HOCKEY CLUB FIELDS & VENUES

11.1 Numbering and Locations

The current list of BHA registered fields can be found on the Internet at www.bha.org.au. A field's appearance in this list does not indicate that it has been passed as suitable for BHA fixtures in the current season but rather is used to assist with the retention of the same field numbering from season to season.

Field No	Field Name	Type	Club / Management	Location/Address	Telephone	UBD Map	UBD Ref.
SHC 1 - 2	State Hockey Centre	Artificial	State Hockey Centre	400-420 Lytton Road, Colmslie	3217 9922	27	A 8
SHC 3 - 8	State Hockey Centre	Grass	State Hockey Centre	400-420 Lytton Road, Colmslie	3217 9922	27	A 8
1 - 6 7 - 7a	ShawSportz ShawSportz	Grass Grass	Shaw Sportz Ltd Shaw Sportz Ltd	East side of Shaw Road, Kalinga Top oval, west side of Shaw Rd, Kalinga	3266 2131 3260 5020	140 140	G 2 F 2
8 - 9	University Oval	Grass	Uni of Qld HC	Uni of Qld, St. Lucia	3870 2710	179	J 5
10 - 12	Dorrington Park	Grass	Northern Suburbs HC	Mirrabooka Road, Ashgrove	3366 5586	138	P 18
13 - 15	Finsbury Park	Grass	Commercial HC	Finsbury Street, Wilston	3356 9411	139	J 18
16	James Drysdale Rec. Res.	Grass	Pine Hills HC	Cnr Jinker Track & Bunya Road, Ferny Hills	3851 2845	117	R 12
26 - 29	South Pine Sports Complex	Grass	St. Andrews Men's HC	South Pine Road, Brendale (opposite Eatons Crossing Road)	-	108	G 11
34	Mary Nairn Fields	Artificial	Redcliffe HC	Cnr Oxley Ave & Lamington Dve, Redcliffe	0412 877 476	91	Q 4
35 - 36	Mary Nairn Fields	Grass	Redcliffe HC	Cnr Oxley Ave & Lamington Dve, Redcliffe	-	91	Q 4
37 - 39	Memorial Oval	Grass	South West United HC	Oxley Road, Graceville	3379 1978	178	L 12
40 - 41	Meakin Park	Grass	Logan HC	Meakin Road, Kingston	3208 8797	242	K 10
BUR 1	Burringbar Park Facility	Artificial	Shaw Sportz Ltd	Way Street, Chermiside (behind the Library on Hamilton Road)	3350 5209	120	B 13
BUR 2 - 3	Burringbar Park Facility	Grass	Shaw Sportz Ltd	Way Street, Chermiside (behind the Library on Hamilton Road)	3350 5209	120	B 13

12 USING THE BHA TEAM & MATCH RECORD SHEETS

This section has its own internal numbering and refers to the Team & Match Record Sheet in Section 13 - **Form 13.6**.

The 2004 Season is now the fourth Season in which the BHA Team & Match Record Books have been in use. They are now used in all Senior Divisions and are being considered for use within Junior Divisions. Initially these books were only used for BHL 1 – 4 (Turf) matches during the 2001 Season. They have been very well received as each Division has progressively been required to use them and the whole exercise has been seen by most as a positive one by BHA.

BHA will supply one book per registered team prior to the commencement of the season. It is hoped that the books will also be used by the Managers of BHA Senior Representative Teams. The aim of the following document is to explain the correct way to use and fill in the Team & Match Record sheets. While filling in the sheets is mostly straight forward and in the main fairly obvious this document seeks to establish practical Association-wide standards. A copy of this document is to be included in each book. Please note that there are new (2004) tick-boxes associated with the 'Umpires' section.

Prior to the Match

There are several sections of the sheet that must be filled in **prior** to the match. These include:

12.1 The Match details

12.1.1 Name of your Club or Team		12.1.2 Division, eg BHL3		12.1.3 Date of the match	
Team:		Division:		Date: / /	
Opposition:		Venue/Field N°:		Time:	
12.1.4 Name of the opposing Club or Team		12.1.5 Field name &/or number, eg SHC1		12.1.6 Start time of match	

12.2 The Players' details

12.2.1 Players' Registration Numbers must be entered here		12.2.3 During the match the time that each player who did not start the match (see 2.2) joined the match is recorded by the Tech Bench here				
12.2.2 Enter a tick beside each of the 11 players starting the match		12.2.4 Shirt numbers must be unique				
	Reg. N°	Start Team ✓	Time Sub On (min)	Shirt N°	USE BLOCK LETTERS ONLY	
				Surname	First name	(Jnr) (C)
1						
2						
3						
12.2.5 These numbers (1 -19) are for guidance, ie (a) a maximum of 16 players may participate in a match; (b) a maximum of three team officials may enter the dugout; (c) therefore a maximum of 19 people may enter the dugout, per team.				12.2.6 Surname first followed by first name for each player and team official		
				12.2.7 Use a bracketed 'C' team Captain & use bracketed 'Jnr' beside registered Juniors		

12.3 The Team Officials' details

16				
17		Team Coach:		
18		Team Manager:		
19		Assistant Coach:		

12.3.1 Enter the name of the Team Coach (if any)

12.3.2 Enter the name of the Team Manager (if any)

12.3.3 Enter the name of the Assistant Coach (if any)

Prior to the commencement of centrally controlled (artificial surface) matches, and in a timely manner, the Team & Match Record Book is to be handed over to the Technical Bench. The Technical Bench will be responsible for the recording of goals scored, a summary of set plays and the details of offences.

In the case of other matches that are not centrally controlled (grass) each participating team should nominate a person on the sideline to record details of the match. In the absence of such persons the books will be handed to the match umpires who will locate the books in a safe place after checking the details on the sheets prior to the commencement of the match. In such circumstances the umpires will be required to keep the scores and to record the scores in the books at half time and full time. Further, in these circumstances, it is not a requirement that umpires record 'Set Plays' however they must record the details of 'Offences' (if any) in full.

During the Match

Only the people named on the sheet will be permitted in the dugout at any time as per the *BHA Competition Rules and Requirements 2003*. When recording the 'minute' that an event occurred (goal scored, card received, etc) the following convention applies: Matches are 35 minutes each way with a 5 minute break, therefore the first minute of the match is recorded as '1', the first minute of the second half is recorded as '41', the last minute of the match is recorded as '75'. Details of the match are recorded as follows.

12.4 Goals and Offences

In each of these columns goals *and* offences are indicated by using the digit '1' for each occurrence for each player (or official). However in the 'Y' column (yellow card) such offences are indicate by using the amount of time (in minutes) given for each offence, usually a '5' or a '10'. These are further summarised in other sections.

12.4.1 Record the per player goals (if any)	Goals	Offences (Cards)		
		G ▲	Y ○	R □

12.4.2 Record the per player and per official cards (if any) that have been received for offences

12.5 Goal Summary

Goal Summary					
Pl;T No	Min	T;p*	Pl;T No	Min	T;p*

12.5.1 The scorer's shirt number is recorded here

12.5.2 The minute when the goal was scored here

12.5.3 Type of goal where:
F or FG = Field Goal,
PC = Penalty Corner,
PS = Penalty Stroke

Each goal scored is summarised in this section. It is a compulsory requirement for centrally controlled matches that these details are recorded. They should be recorded during the match.

12.6 Set Play Summary

Set Plays are Penalty Corners and Penalty Strokes. These should be recorded during centrally controlled matches by the Technical Bench. In each of the appropriate areas Penalty Corners and Penalty Strokes are indicated by using the digit '1' for each occurrence.

Set Play Summary	
Penalty Corners	Strokes
1st Half	
2nd Half	

12.7 Misconduct & Offence Summary

Where possible offences should be summarised during the course of the match. However it will be necessary on some occasions for the Technical Bench to query the Umpire at half time or full time regarding the nature of some offences.

Misconduct & Offence Summary					
Pl:r No	Min	Type	Pl:r No	Min	Type

12.7.1 The offender's shirt number is recorded here

12.7.2 The minute when the offender received the card

12.7.3 The type of card received, eg 'Y1' – see below

12.7.4 If 'Y5' – record a brief description here

12.7.5 If 'R4' – record a brief description here

Misconduct & Offence Types

Yellow Cards: Y1 - Bad Tackling; Y2 - Obstruction; Y3 - Deliberate breach; Y4 - Swearing; Y5 - Other

Red Cards: R1 - Deliberate dangerous play; R2 - Striking opponent; R3 - Obstruction/Abuse; R4 - Other

After the Match

At the conclusion of the match the following actions are required:

12.8 Checking & Signing

12.8.1 It is the responsibility of each of the captains of the opposing teams to check that the details of the match have been correctly recorded on both teams' sheets. Once satisfied each captain is to sign in the spaces provided on both teams' sheets.

12.8.2 The match umpires are also required to check that the details of the match have been correctly recorded on both teams' sheets. Once the umpires are satisfied with the details they will each record their name, umpire number and signature in the spaces provided. Umpires must also each indicate their 'Type' with a tick, i.e. whether they are *Official*, *Listed Back-up* or *Stand-in*.

Official umpires are those with official qualifications and will have generally been assigned to the match by BHUA. *Listed Back-up* umpires are those who have umpired the match on behalf of the club listed to do the match as per the BHA Fixture Draw. *Stand-in* umpires are those called upon to 'stand-in' when neither an Official nor the Listed Back-up umpires have umpired the match. However, if by mutual agreement a person agrees to stand-in on behalf of a listed club then the *Listed Back-up* box should be ticked. Generally, when a completed sheet is received in the BHA Office with the *Stand-in* box ticked it means that the listed club on the BHA Fixture Draw shall receive an 'automatic penalty'. (Refer Rule 2.11)

12.8.3 The attending First Aid Officer is to record their name, their starting and finishing times and their signature in the spaces provided. In the case where they are attending to matches on more than one field at the same time (e.g. grass venues) the First Aid Officer is required to sign at least one of the Team & Match Record sheets for that timeslot. Failure to do so may result in the non-payment of the particular First Aid Officer concerned.

12.8.4 Finally, at all centrally controlled matches (e.g. artificial surfaces), the Technical Officers will also check over the sheets of both teams. Once satisfied they will record their name and their signature in the spaces provided on both teams' sheets.

Once completed and signed it is an offence for any further alterations to be made to the sheets.

12.9 Completed Sheets

Once the sheets have been completed, checked and signed as described, the "original" (white) copy is removed from each team's book while the carbon (coloured) copy is retained in the book for the teams' and the clubs' records. The "original" copies must be dealt with as follows:

12.9.1 At centrally controlled venues it is the responsibility of the Tech Officer/s to see that the "originals" from the match are returned to the venue office immediately following the match. Should there not be a Tech Officer then this becomes the responsibility of the match umpires.

12.9.2 At other venues (grass) it is the responsibility of the match umpires to see that the "originals" are returned to the venue office or canteen. However, should this not be possible (e.g. canteen closed) then it becomes the responsibility of the match umpires to see that the "originals" are returned to the BHA Office by way of a safe and secure manner as soon as is possible. The postal address of BHA Inc is PO Box 503, MORNINGSIDE Q 4170

13 BHA COMPETITION FORMS

The following pages contain copies of various prescribed forms referred to throughout these rules.

Form 13.1 is the "Application for the Registration of Club Teams" form and is used prior to the commencement of the season to apply for the registration of a club's teams for that season. Club Secretaries will be advised of the closing date for the submission of this form.

Form 13.2 is the "Team Registration Form" form and is to be submitted by the commencement of the season's fixtures for each of the respective division/s or competition/s. This form is to be completed team and submitted prior to the commencement of fixtures and declares the registered division/team of each player.

Form 13.3 is the "Player Registration Re/De-registration Form" and is used after the commencement of the season's fixtures to register new players, to alter the registered division/competition details of an existing player or to remove a player from the list of registered players of a club.

Form 13.4 is an example of a "Member Registration" form typically used to register a player with a club and therefore with the Association. It is important that players be registered in this way. The player insurance policy currently in place requires that for players to be covered they must be registered with the Association.

Form 13.5 is the "Incident Report" form. This form is the prescribed form to be used by persons wishing to report an incident of misconduct of players, club officials and others in and around dugouts and matches, not otherwise reported or dealt with by the match umpires.

Form 13.6 shows a "Team & Match Record" sheet. These sheets are now used in book form (duplicates) as a replacement for the more traditional Team Cards of the past. Instruction sheets for their use were handed out with each of the books prior to the season.

13.1 Application for the Registration of Club Teams

Brisbane Hockey
Association IncAPPLICATION FOR THE
REGISTRATION OF CLUB TEAMS2004
F13.1

THE GENERAL SECRETARY
BRISBANE HOCKEY ASSOCIATION INC
P.O. BOX 503
MORNINGSIDE Q 4170

The _____ Hockey Club Inc* hereby applies for registration with the Brisbane Hockey Association Inc. for the 2004 season, subject to the Rules and By-laws thereof. Should these registrations be granted, the Club undertakes to be bound by such Rules and By-laws.

The fee of \$22.00 (inc GST) per existing team is to accompany this form, however in the case of additional (new) team/s, the non-refundable fee of \$350.00 (inc GST) per team is to accompany this form.

The information required by the Association in relation to our club is detailed hereunder.

The _____ Hockey Club Inc* applies to enter a total of _____ Team/s. The number of Team/s nominated in each Division is indicated below:

TEAMS IN 2003

BHL 1 (Turf)
BHL 2 (Turf)
BHL 3 (Turf)
BHL 4 (Turf)
CHL 1 (Grass)
CHL 2 (Grass)
CHL 3 (Grass)
VETERANS (Turf)

TEAMS IN 2004

BHL 1
BHL 2
BHL 3
BHL 4
CHL 1
CHL 2
CHL 3
VETERANS

Our Club uniform is

.....
.....

Enclosed please find cheque / money order to the value of \$..... as per the details shown above.

Signed(Honorary Secretary) Date/...../.....

Name

THIS FORM AND THE APPROPRIATE PAYMENT MUST BE RETURNED TO THE GENERAL SECRETARY OF THE BRISBANE HOCKEY ASSOCIATION INC. YOUR RETURN SHOULD BE EITHER BY MAIL TO THE ABOVE ADDRESS OR IN PERSON TO THE OFFICE OF THE BRISBANE HOCKEY ASSOCIATION INC AT THE STATE HOCKEY CENTRE, COLMSLIE - NO LATER THAN FRIDAY 28th NOVEMBER 2003.

(* cross out 'Inc' if not applicable to your club)

13.2 Team Registration Form



Brisbane Hockey Association Inc.
AFFILIATED WITH HOCKEY QUEENSLAND INC.

Team Registration Form

THIS FORM IS TO BE COMPLETED, SIGNED BY THE CLUB SECRETARY AND SUBMITTED TO THE BHA SECRETARY ALONG WITH THE APPROPRIATE FEES **PRIOR TO THE COMMENCEMENT OF FIXTURES**. THE FORM IS USED TO INITIALLY REGISTER INDIVIDUAL PLAYERS TO THEIR RESPECTIVE TEAM & DIVISION. TO RE-REGISTER A PLAYER TO ANOTHER DIVISION USE THE 'PLAYER REGISTRATION RE/DE-REGISTRATION FORM'. (REFER TO BHA COMPETITION RULES & REQUIREMENTS)

CLUB:	SEASON 2004
-------	-------------

In accordance with By-laws, approval is requested for the Registration of the following Players as members

of our **Division Team**. This team will compete as (e.g. Tigers, NorCom, etc)

Notes: 1) Please list players in alphabetical order with the Surname in block letters. 2) For Reg. No. refer to Member Reg Forms.

3) A minimum of eleven (11) players must be registered per team. 4) Players must not be registered with more than one team in the same competition. 5) **A Fee of \$100 per Player** (Insurance & part Hockey Qld levy) **must accompany this form.**

No.	SURNAME	INITIAL	FIRST NAME	REG. NO.
1				
2				
3				
4				
5				
6				
7				
8				
9				
10				
11				
12				
13				
14				
15				
16				

.....
Signature of Club Secretary

.....
Date

.....
Name (Block Letters)

The Secretary, Brisbane Hockey Association Inc, PO Box 503, MORNINGSIDE Q 4170
Ph: +61 7 3899 4399 Fax: +61 7 3399 9825 Email: secretary@bha.org.au

13.3 Player Registration Re/De-registration Form



PLAYER REGISTRATION RE/DE-REGISTRATION FORM

F13.3

To: The Secretary
Brisbane Hockey Association Inc
P.O. Box 503
MORNINGSIDE Q 4170

Use this form when:

1. Registering a new player after the initial registrations for the season have been submitted to BHA.
2. Re-registering a player to a different division/competition.
3. De-registering a player, i.e. player will no longer play for club.

On behalf of the _____ Hockey Club I hereby submit this application

for the 1. Registration /

2. Re-registration /

3. De-registration - of the Player whose details are as follows:

(Please Z that which applies) (In the case of 1 and 2 about the Member Registration Form (Form Max File) database must be updated and reset to BHA)

● Personal Details:

Full Name: _____

Date Of Birth: ____ / ____ / ____

Private Address: _____

Postcode: _____

● Registration Details:

To be registered in _____ Division / Competition.

This player was previously registered with _____ Hockey Club (if applicable).

Clearance attached (if applicable). Refer to 3.9 of the BHA Competition Rules & Requirements.

Comments: _____

● Re-registration Details:

From: _____ Div/Comp **To:** _____ Div/Comp

It is necessary to re-register this player for the following reason: _____

● De-registration Details:

To be de-registered from _____ Division / Competition with our club.

X Signature: _____ (Club Secretary) **Date:** ____ / ____ / ____

This form to be completed & sent to The Secretary, Brisbane Hockey Association Inc
PO Box 503 MORNINGSIDE Q 4170 - Telephone: 3899 4399 - Facsimile: 3399 9825 - Email: secretary@bha.org.au

13.4 Member Registration Form (Typical)

Brisbane Hockey Association Inc

 (AFFILIATED WITH HOCKEY QUEENSLAND INC)
 ABN: 43 857 681 225

Member Registration Form

Senior Men's BHL, CHL & Veterans Teams Only

OFFICE USE ONLY

YEAR:

REG No:

This form is to be completed, signed and dated by all members over 18 (or by a parent or guardian if under 18) and then submitted to the member's Club Secretary. The details contained in this form must then be submitted to the BHA Secretary/General Secretary before the member is eligible to participate in any BHA Fixture or Competition. The details contained herein are required for insurance purposes.

PERSONAL DETAILS				PLEASE USE BLOCK LETTERS	
GIVEN NAME:	INIT:	SURNAME:	D.O.B.:		
ADDRESS:					
SUBURB:		STATE:	POSTCODE:		
TELEPHONE HOME:	WORK:		MOBILE:		
EMAIL: (preferred)		OCCUPATION:			
PLAYING DETAILS				PLEASE USE BLOCK LETTERS	
CLUB/S (this year)	PRIMARY	DIVISION	SECONDARY (if applicable)		DIVISION
CLEARANCE Obtained?	<input type="checkbox"/>	PREVIOUS CLUB/CENTRE: <small>Note: If this is your first season with the above club after having played with another club you are required to obtain a Clearance from your previous club.</small>			
JUNIOR (Please tick only that which applies, if any)	I AM UNDER 17 AS AT 1st JAN OF THIS CURRENT YEAR:		<input type="checkbox"/>	I AM REGISTERED TO PLAY IN JUNIOR DIVISION/S:	
DUAL REG Required?	<input type="checkbox"/>	PRIMARY CENTRE	SECONDARY CENTRE		A HQ Dual Reg Form is also to be completed
ACCREDITATIONS & QUALIFICATIONS (if applicable)				PLEASE USE BLOCK LETTERS	
IF COACHING THIS YEAR, WHICH TEAMS:					
COACHING LEVEL: (if applicable)					
UMPIRING BADGE OR QUALIFICATION:		FIRST AID QUALIFICATION:	TECHNICAL OFFICER QUALIFICATION:		
I AM CURRENTLY A MEMBER OF: A.I.S. <input type="checkbox"/> Q.A.S. <input type="checkbox"/> <small>Note: Special conditions may apply. Please refer to the Declaration below and to the Hockey Queensland Dual Registration Form for further information.</small>					
DECLARATION					
I hereby agree to abide by the Brisbane Hockey Association Inc Rules, By-laws, Competition Rules and/or policies.					
I hereby register as a Primary* Member of the Brisbane Hockey Association Inc for the purposes of Hockey Queensland Inc registration and therefore will be available for Brisbane Hockey Association Teams should I wish to compete in any Hockey Queensland Championship or Tournament and that I may not offer my services to any other centre without the prior written consent of the Board of the Brisbane Hockey Association Inc.					
Further I agree that should I wish to seek Dual Registration with Brisbane as the Secondary Centre I will apply in writing to the B. H. A. Secretary, and that upon receipt, such applications will be considered by the BHA Board at its next scheduled meeting.					
Signature of Player, Official, or Parent/Guardian (if Under 18)			Date		
Name of Parent or Guardian who has signed above (Print)			Relationship to Under 18 Player		
Notes: <ol style="list-style-type: none"> 1. Players not selected in a Brisbane Representative Team may nominate to represent other Centres. 2. Players who are not registered as Primary Brisbane will not be eligible for BHA Best & Fairest points. 3. When changing Clubs or Centres a written Clearance from the previous Club must be provided to the new Club. 					
OFFICE USE ONLY	FORM SIGNED: (Date)	DUAL REG FORM COMPLETED:	<input type="checkbox"/>	DATA ENTERED BY:	

 The Secretary, Brisbane Hockey Association Inc, PO Box 503, MORNINGSIDE Q 4170
 Ph: +61 7 3899 4399 Fax: +61 7 3399 9825 Email: secretary@bha.org.au

13.5 Incident Report



INCIDENT REPORT

The Secretary
Brisbane Hockey Association Inc
P.O. Box 503
MORNINGSIDE Q 4170

I/We wish to report the following incident to the Board of Management of the Brisbane Hockey Association.

Match Details

Venue: _____ Date: ___/___/___ Time: ___ : ___

Teams: _____ (TEAM) versus _____ (TEAM)

Alleged Offender Details

Name: _____ Shirt Number: _____ (if applicable)

Club: _____

Misconduct Type

Please ✓ those that apply

- and**
- | | |
|---|--|
| <input type="checkbox"/> (a) Abuse of umpire | <input type="checkbox"/> (b) Abuse of player |
| <input type="checkbox"/> (c) Abuse of Tech Official | <input type="checkbox"/> (d) Swearing |
| <input type="checkbox"/> (e) Other: _____ | |

Further Details (if applicable)

Reporter's Details & Signature

(PRINT FULL NAME) (CONTACT NUMBERS)

(SIGNATURE) (DATE)

13.6 Team & Match Record



Brisbane Hockey Association Inc

TEAM & MATCH RECORD

Team:	Division:	Date: / /
Opposition:	Venue/Field N°:	Time:
Result: Win <input type="checkbox"/> Draw <input type="checkbox"/> Loss <input type="checkbox"/> Forfeit <input type="checkbox"/>		Goals For: Goals Ag:

(✓ that which applies above)

	Reg. N°	Start Team ✓	Time Sub On (min)	Shirt N°	USE BLOCK LETTERS ONLY			Goals	Offences (Cards)		
					Surname	First name	(Jnr) (C)		G ▲	Y ○	R □
1											
2											
3											
4											
5											
6											
7											
8											
9											
10											
11											
12											
13											
14											
15											
16											
17			Team Coach:					-			
18			Team Manager:					-			
19			Assistant Coach:					-			

A maximum of 19 named personnel are permitted in the digout area

Plyr No	Min	Type	Plyr No	Min	Type

Penalty/ Corners	Strokes
1st Half	
2nd Half	

Plyr No	Min	Type	Plyr No	Min	Type

Misconduct & Offence Types

Yellow Card: Y1 - Bad Tackling; Y2 - Dissent; Y3 - Deliberate breach; Y4 - Swearing; Y5 - Other

Red Card: R1 - Deliberate dangerous play; R2 - Striking opponent; R3 - Dissent/Abuse; R4 - Other

Captains

Sig:

Sig:

Umpires

Name: No: Sig:

Name: No: Sig:

Indicate Ump Type: Official Limited Back-up Stand-in

Indicate Ump Type: Official Limited Back-up Stand-in

First Aid

Name: Start time: Finish time: Sig:

Tech Officers

Name: Sig:

Name: Sig:

©2004 BHA